

OPERATOR'S MANUAL



CLARK TRACTORS CTE 7, CTE 12, CTE 20

OPERATOR'S MANUAL

OI-797 GB

INDEX

1. SECURITY REGULATIONS.....	3
General norms.....	3
2. SECURITY REGULATIONS.....	4
Security respect to the tractor.....	4
Daily inspections.....	5
Control instruments.....	7
The tractor operator.....	7
Movement on slopes and in special areas.....	8
Transport of the tractor.....	9
Functional testing.....	10
Trailing the tractor.....	10
Noise level.....	10
MODEL.....	10
3. CONTROL AND INDICATOR PANEL.....	11
5. LOADING AND UNLOADING OPERATIONS.....	14
6. MAINTENANCE AND PREVENTIVE CONSERVATION.....	15
Brakes.....	15
Fuses.....	15
Periodic maintenance.....	16
Lubricants.....	18
Batteries.....	19
Wheels.....	21
7. EXTENDED STORAGE.....	23
8. TABLE OF THE CHARGES AND TECHNICAL SPECIFICATIONS.....	24
Identification.....	24
Specifications.....	25
TECHNICAL CHARACTERISTICS TRACTOR CTE-7 CTE-12 CTE-20.....	26

Clark Material Handling GmbH
Rheinstraße 19-23
45478 Mülheim (Ruhr)
Deutschland
Tel. 0049 208 588-0

1. SECURITY REGULATIONS

General norms



WARNING

Precautions when opening and closing the battery cover.

To open or close the battery cover, do so using the handle. If you hold the cover on the other side, you can hurt your fingers.

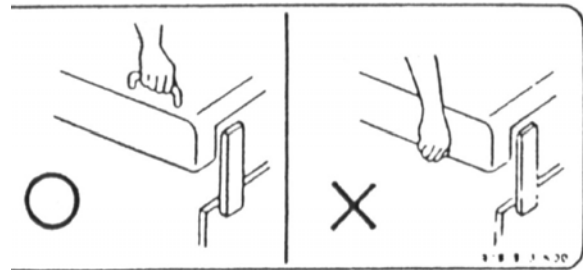

WARNING

Precautions during the operation

This label contains instructions referring to how to handle the tractor in a secure way and avoid any possibility to have an accident. So please assure that these instructions are strictly observed before starting up the tractor.

PRECAUTIONS WHEN LOADING

1. Carry out the loading operation in a well-ventilated area, away from any heat source and from sparks (the gas produced by the battery can be explosive).
2. Do not smoke near the loading area.
3. Open the battery cover and fix it firmly during the loading procedure.
4. Do not disconnect the connector during the loading process, as this could produce sparks.

WARNING

Observe the disposition of the pedals.

The disposition of the pedals to control the tractor is shown on the figure.

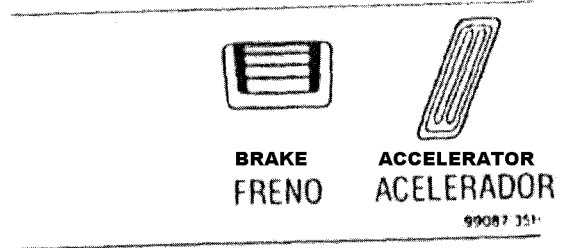

WARNING

How to assure the battery cover.

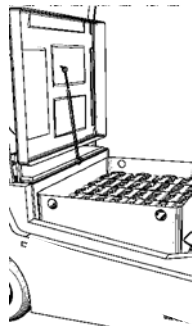

The way to open, close and assure the upper panel is shown on the figure. Lift the cover and fix it so that it remains in a completely vertical position.

There can be a risk of hydrogen accumulation on the battery.

WARNING

ONLY EMERGENCIES

This switch is used to disconnect the battery only in emergency cases.

An excessive use of this switch could cause damage to the electric system.

The seat has a security device, which avoids the tractor to move in the case it is not occupied by its driver, in the supposition of a horizontal surface.

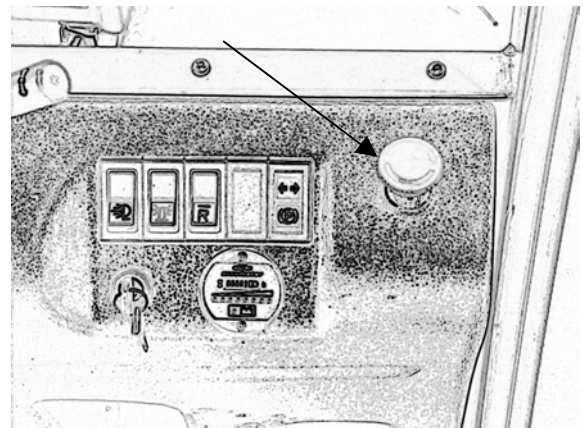

2. SECURITY REGULATIONS

Security respect to the tractor

USE ACCORDING TO THE PRESCRIPTIONS

The tractors can only be used according to the prescriptions, and observing the present service instructions.

WARNING

The tractors are only destined to haul loads in the conditions indicated in this manual.

WARNING

If you wish to use the tractor for other uses, so as to avoid any risk, you should get CLARK's authorisation, and if it is pertinent, that of the corresponding authority.

These prohibitions are not applicable in the cases when the tractors are especially equipped for such jobs.

STABILITY

The CLARK tractors are completely stable when driven or in their working position, whenever they are used in a correct way and the transported loads are allowed

The trailing capacity of your CLARK tractor should never be surpassed. It would endanger its braking capacity.

PROTECTION OF THE DRIVER

The protecting roof accomplishes with the ISO 6005 norm respect to the protection against falling objects.

Daily inspections

Before starting the tractor operation, the following points should be inspected:

1. Brake circuit: liquid level; examine possible escapes in the circuit.
2. Wheels: wear and state of the tyres; tightening of the wheel fastening screws.
3. Battery: level of the electrolyte.
4. Steering: The flywheel play.
5. Control instruments: Put the switch key in the position "I", i.e. switched on; verify that the control light lights up at the upper part of the hour-meter indicator of the battery.
6. Indicators: verify the correct operation of the horn, lights and indicators.
7. Brakes: verify the correct operation of the service brakes and the parking brakes.

Level of the braking liquid

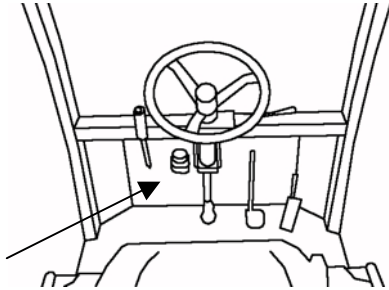

Visual inspection of the brake fluid level. It should be somewhere between the maximum and minimum, indicated on the tank.

Check for possible escapes in the brake circuit pipes.

WARNING

Only use the specified brake fluid.

WHEELS

Size of the wheels	
Front	Rear
400-4 (CTE7) / 16-6x8 (CTE12,CTE20)	18-7x8 (CTE7) / 21-8x9 (CTE12,CTE20)

Torque		
Wheel nuts	Front	150 Nm
	Rear	

BATTERY

See procedure to open the cover.

1. Verify there are no electrolyte escapes and that the terminals are not corroded.
2. Verify the electrolyte level. Verify the level through the filling opening. The distance from the electrolyte to the upper edge of the opening should not be more than 60 mm.

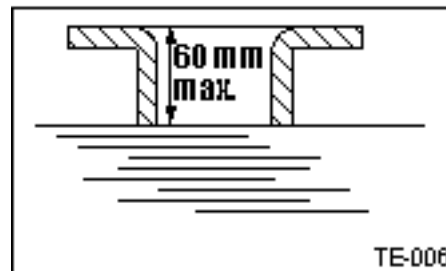

WARNING

It is recommended to use special glasses and gloves when manipulating the battery.

STEERING

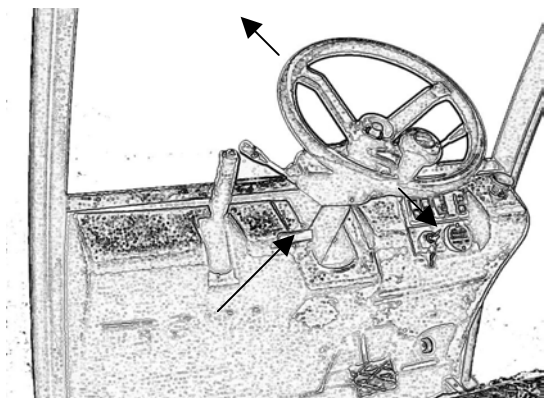

Regulation of the steering column inclination.

Unlock, pulling the blocking lever up. Regulate the flywheel inclination to the wished position. Lock the column again by pressing the blocking lever down.

Control instruments

INDICATORS

1. Press the horn.
2. Verify that the reversing acoustic signal works.

BRAKES

1. Place the start up switch in forward position. Press the accelerator softly down. Brake with the service brake, verifying its correct operation.
2. Repeat the operation for reversing.
3. Verify the correct operation of the parking brake.

To activate the parking brake, pull the lever back.

To release the brake, unblock the trigger and push the lever forward.

The parking brake disconnects the traction control system, so that the tractor cannot be moved.

The tractor operator

QUALIFICATION OF THE OPERATOR

WARNING

The tractor should be handled according to its instruction manual and accomplishing with the regulation provisions of your country.

PROTECTION CLOTHING FOR THE TRACTOR OPERATION.

WARNING

When operating the tractor, use protective clothing according to the work conditions and accomplishing with the regulation provisions of your country.

The operator's working clothing should have its sleeves and legs sufficiently tight to avoid the possibility of being caught in the tractor levers. The operator should also wear protecting glasses, ear protectors and a mask against dust as well as security shoes, if the operation regulation of the firm requests so.

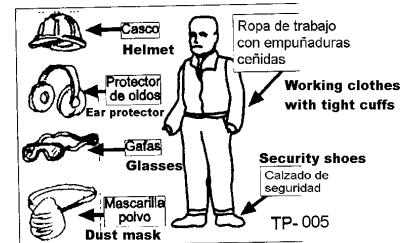

Movement on slopes and in special areas

WARNING

Drive slowly and with care on slopes.

When operating loaded on slopes, always drive forward, both to go up and to come down.

WARNING

Do not turn round on the slope.

MOVEMENT

Visibility

Verify that there is enough light in the working area of your tractor.

OVERTURNING DANGER

In the case of overturning risk:





The tractor can incline laterally if it is operated in an inadequate way. Do not risk unnecessarily. **Reduce speed when turning!**

Fasten your security belt and remain in your seat.

IN THE CASE OF OVERTURNING RISK:

Follow these instructions:

1. Incline to the opposite side
2. Hold the flywheel and incline your legs
3. Do not jump out!

 In the case of overturning risk EN CASO DE IR A VOLCAR			
		<p>The hauling tractor can incline laterally if it is operated in an inadequate way. Do not risk unnecessarily. Reduce speed when turning!</p>	
		<p>Fasten the security belt and stay in your seat.</p>	
IN THE CASE OF OVERTURNING RISK Follow these instructions:	 <p>Incline to the opposite side</p>	 <p>Hold the flywheel and tense your legs</p>	 <p>Do not jump out!</p>
TS-011			

Transport of the tractor

WARNING

1. Confirm the entrance and outgoing angles to assure that the lower part does not interfere with the ground or the transport platform.
2. When a bridge is used between the quay and the loading platform, confirm that the planks are strong enough to support the tractor weight.
3. When the tractor is towed with a capstan towards the transport platform, be sure to fix the cable to the hooking angle. Do not mount on the tractor during the haulage with the capstan.
4. Be sure to use only the foreseen fastening points and fix the tractor firmly to the transport platform.
5. When the tractor is lifted, be sure to use the foreseen lifting points.
6. Disconnect the contact key and take it out.
7. Be sure that the battery connector is disconnected.

Functional testing

Functional tests are to be carried out to verify that the tractor operates correctly after having been transported, or after a long storage period. There are two kinds of tests:

1. Tests which are indicated in the daily inspection to be carried out by the user.
2. Dynamic testing, to be carried out by the CLARK concessionaire.

Mobility testing (movement)

Confirm that the tractor moves in the sense specified by the forward-backward movement switch, and that the operation or release of the parking brake lever works well. Also, inspect that the flywheel works in a satisfactory way.

Trailing the tractor

Use the towing bar when the wheels get in a gutter or trench or when the tractor is loaded on a transport platform.

Be sure to insert the towing bar until it remains well fixed with the towing angle.

WARNING

Be extremely careful when using the towing bar or cable.

The towing bar is used to take the tractor out of trenches with a towing trailer.

Use the towing bar to fasten the tractor during the loading operation on a platform.

WARNING

Do not use the towing bar to tow heavy objects.

Use adequate metal cables which are in good state.

Avoid sudden movements. Tow gently. A sudden towing can cause load movement or that the towing bar gets bent.

Noise level

MODEL	NOISE LEVEL
CTE7, CTE12, CTE20	Less than 70 dB(A)

3. CONTROL AND INDICATOR PANEL

OPTICAL INDICATORS AND REFERENCE POINTS

Battery charge level measuring device

This measuring device is built up of eight amber lights. The number of lights lit indicates the level of the battery charge. The last light indicates that there is only 20% of battery charge left.

Hour-meter

The hour-meter has six digits. The left five are for the hours and the last digit right for the tenths of the hour. It works when the contact key is connected.

Truck pilot light

This light lights when the contact key is switched to the position "I" i.e. connected. Should it not light, being there some measuring light on corresponding to the battery charge capacity, then verify the bulb.

SWITCHES

CONTACT KEY

There are two positions "O" and "I".

The position "O" is the one when all the circuits are disconnected.

The position "I" is the one to start the tractor up. When the key is put in this position, the amber indicating lights indicating the battery charge will light up as well as that of the hour meter.

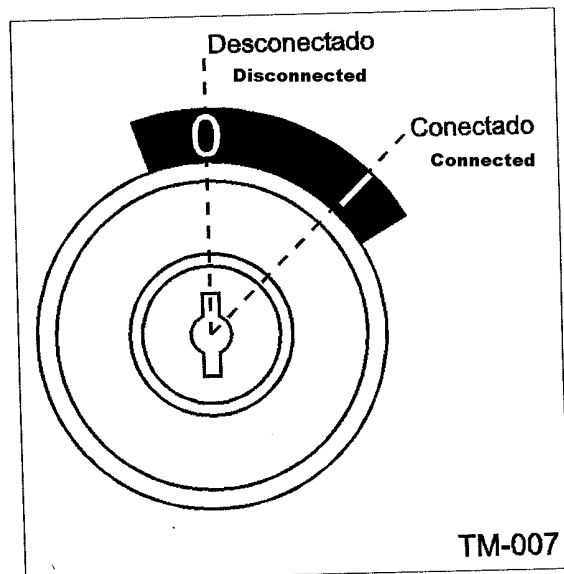

WARNING

Before you abandon the driving position, always put the parking brake on.

HORN

The horn push button is situated on the lever to the right of the driver, and it sounds when it is pressed.

4. STARTING UP AND HANDLING

FORWARD AND BACKWARD MOVEMENT SWITCH

Once the forward and backward movement switch is situated on the wished position, press the accelerator pedal.

When you drive backward, an acoustic warning device will sound.

PARKING BRAKE LEVER

To brake, pull the hand brake lever backwards. To release the brake, push it forward.

WARNING

Before you abandon the tractor, always put on the parking brake and take away the contact key.

PEDALS

Service brake pedal

It is situated at the lower part and to the right of the steering column.

WARNING

Always use your right foot to actuate the brake pedal.

Accelerator pedal

It is situated to the right of the brake pedal.

WARNING

To avoid sudden movements, always actuate the accelerator pedal after connecting the contact key. Before accelerating, verify that the forward-backward movement lever is in the wished position.

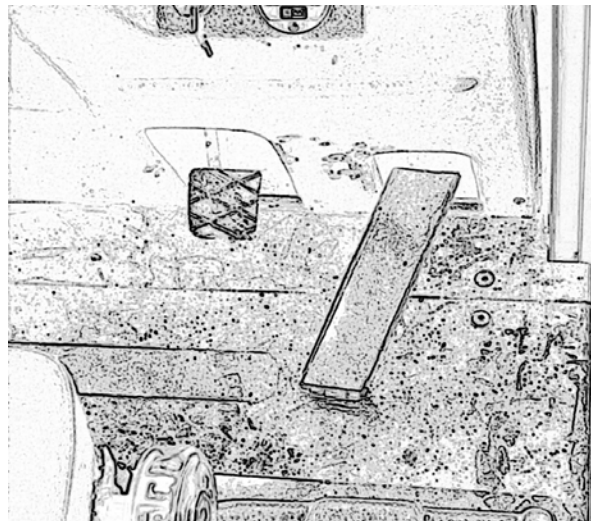

INCLINATION OF THE STEERING WHEEL

To adjust the steering wheel position, unblock the column by pulling the lever situated at the lower left part of the steering column up and incline the flywheel to the wished position. Next, push the lever down to block it.

WARNING

The adjusting of the steering wheel inclination should only be carried out with the tractor stopped.

Once adjusted the steering wheel position, be sure that it is firmly blocked.

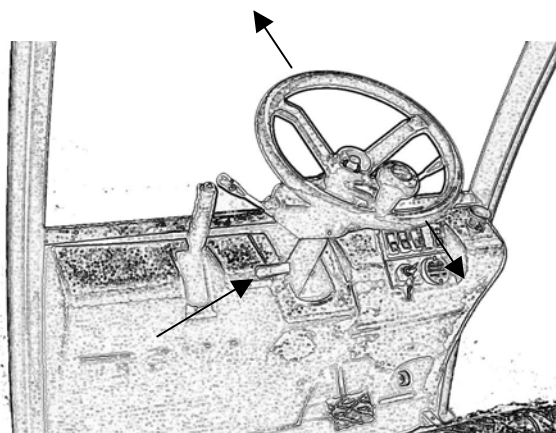

BATTERY CONNECTOR

It is used to feed the C.A. engines, auxiliary circuits, etc... by means of the batteries.

If an abnormal situation happens, it should be disconnected immediately.

It should be disconnected before changing or inspecting the fuses in other electric components.

REGULATION OF THE DRIVER'S WEIGHT

To adjust the seat to the driver's weight, turn the rotary command until the wished value is indicated.

OPENING AND CLOSURE OF THE UPPER PANEL

1. Place your hand in the recess foreseen in the cover.
2. Lift the cover and be sure that it remains in a completely vertical position, so that the damper avoids its possible falling.

START UP AND OPERATION

WARNING

Before making use of the tractor, carefully read all the security rules related to its use.

1. Verify that the parking brake is on.

2. Be sure that the battery connector is connected.
3. Put the contact key into position "I" without pressing the accelerator.

WARNING

Do not put the contact key on "I", if the parking brake is not on.

4. Be sure that you have enough battery charge, by watching the amber indicating lights, which indicate its capacity.
5. Place the forward-backward movement lever into the wished position. Verify that the way is free and press the accelerator gently down.

Turning

The sharper the bend to be carried out, the lower the tractor speed should be.

Stopping and parking

To stop the tractor, release the accelerator and press the service brake pedal gently. Do not carry out sudden stops as this can produce load movement.

WARNING

When you abandon the tractor, always apply the parking brake and take away the contact key.

LOW VOLTAGE BLOCKING SYSTEM

When the last indicating light of the hour-meter indicator of the battery lights up only 20 % of the battery charge remains, so that it should be charged. If you continue operating without charging it, you will only be able to move the tractor to remove it.

CLIMATOLOGIC CONDITIONS FORESEEN TO WORK WITH THE TRACTOR

In its present configuration, the tractor is foreseen to work inside.

Should you wish to work outside, it should be cabined.

5. LOADING AND UNLOADING OPERATIONS

LOADING

Slowly approach the load in reverse and stop in front of it. Apply the parking brake.

Adjust the hooking.

Place the switch in forward movement, release the parking brake and advance slowly.

UNLOADING

Slowly approach the unloading place frontally

Apply the parking brake.

Release the fastening hook.

6. MAINTENANCE AND PREVENTIVE CONSERVATION

Brakes

BRAKE PEDAL

The free play of the brake pedal should not be higher than 10 mm.

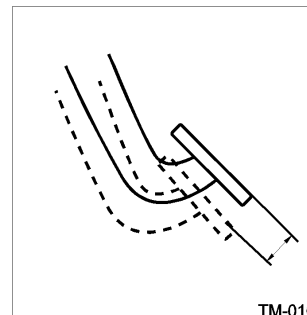

PARKING BRAKE

Be sure that the parking brake works well by actuating the lever and putting it back into its original position.

In the case of an incorrect operation, have the brakes inspected by CLARK.

Fuses

FUSES

WARNING

Before inspecting the fuses, disconnect the battery connector.

Put the contact key into position "I" i.e. switched on and wait for 30".

Put the key back to position "O".

Substitute the fuses for others with the same amperage.

Periodic maintenance

GUIDE TO A PERIODIC MAINTENANCE

Before the delivery of the new tractor, the Concessionaire carries out a pre-delivery check and an adjusting service specified by the Factory, with the purpose that the tractor renders the wished services.

On the following tables, the required maintenance services to get a satisfactory operation of the lifting tractor are indicated. These services should be carried out by a Concessionaire or an Official CLARK Service.

WARNING

Only spare parts approved by Clark may be used.

Traction control system

WARNING

Do not review any system component while the battery is being charged.

Put the contact key into position "I" i.e. connected and wait for 30".

Put the key back into position "O".

When it is necessary to carry out some verification with the battery connected, lift the driving wheels. Take special care that no electric discharge occurs.

CONTROL AND TRACTION EQUIPMENT

Control and traction equipment													
Maintenance operation	MAINTENANCE INTERVAL												
	MONTHS	1	2	3	4	5	6	7	8	9	10	11	12
	HOURS X 100	2	4	6	8	10	12	14	16	18	20	22	24
The maintenance operations should be carried out at the indicated monthly or hourly periods, depending on which occurs first													
1. Clean the outside of the traction engine							●						●
2. Verify the electric resistance between the chassis and the battery terminals				●			●			●			●
3. Clean the surface of the control unit		●		●			●			●			●
4. Verify the cables, screws and nuts		●		●			●			●			●
Verify: this includes repair and substitute whenever this is necessary													

CHASSIS AND FRAME

Control and traction equipment													
Maintenance operation	MAINTENANCE INTERVAL												
	MONTHS	1	2	3	4	5	6	7	8	9	10	11	12
	HOURS X 100	2	4	6	8	10	12	14	16	18	20	22	24
The maintenance operations should be carried out at the indicated monthly or hourly periods, depending on which happens first.													
1. Verify the free play of the brake pedal		●		●			●			●			●
2. Verify the operation of the parking brake		●		●			●			●			●
3. Line up the wheels													●
4. Verify the free play of the brake disks		●		●			●			●			●

5. Verify the operation of the flywheel	•		•		•		•		•
6. Verify the oil level of the traction gears	•		•		•		•		•
7. Substitute the oil of the traction gears									•
8. Substitute the brake fluid					•				•
9. Grease the front wheel running gear			•		•		•		•
<p>Verify: this includes repair and substitute whenever this is necessary</p> <p>Should you work in dusty or dirty conditions, a more frequent maintenance is necessary</p>									

Lubricants

RECOMMENDED LUBRICANTS

DESIGNATION		SPECIFICATIONS	OBSERVATIONS
Gear oil	Traction reducer	API GL-4	Consult the TABLE OF RECOMMENDED VISCOSITIES
	Steering shaft bearing	N.L.G.I. No 1	Based on lithium soap
Grease	Wheel running gear	N.L.G.I. No 2	
	Brake fluid		DOT-4
RECOMMENDED SAE VISCOSITIES		<p>ACEITE PARA ENGRANAJES Bearing lubricating oil</p> <p>Viscosity of the oil to be used according to the environment temperature</p> <p>TT-008</p>	

WARNING

The oil used should be discarded according to what is indicated in the Regulations of each country.

Batteries

MAINTENANCE AND CARE OF THE BATTERIES



WARNING

Observe the operation instructions of the battery manufacturer and of the battery charger manufacturer.

These charging operations should exclusively be carried out by specialised staff. The use of protective glasses and gloves is recommended.

The room should be well ventilated. Smoking is forbidden, as the gas that is given off is inflammable.

BATTERY CHARGING

General precautions

1. Put on the parking brake.
2. Lift the upper panel.
3. If several loaders are available, be sure that the charging tension corresponds to that of the battery.
4. Before charging the battery, verify that the water covers at least the battery jar grid, always adjust the water level after loading.
5. Once the charging operation is completed, verify with a densimeter that the specific weight is 1,28 at a temperature of 20 degrees (see battery manual).

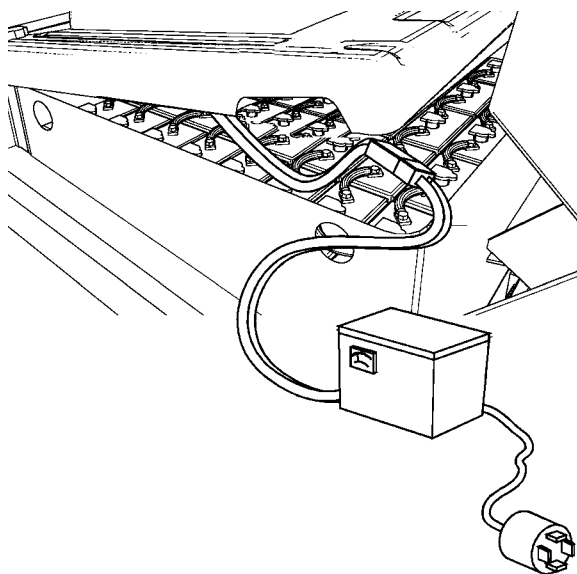

BATTERY SUBSTITUTION

Disassembly and assembly

To disassemble the battery follow the following instructions:

1. Disconnect the battery connector.
2. Lift up the cover, holding it at the handle.
3. When lifting the cover, be sure that it remains completely in vertical position.
4. Lift the protecting roof trap. Line up the battery-lifting device with the tackle and the protecting roof. Preferably, use a rigid lifting device (yoke). Should this not be possible, seek that the lifting slings are maintained as vertical as possible, so as to avoid damage to the battery receptacle.

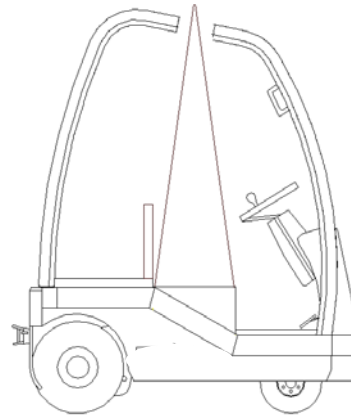

WARNING

The lifting slings should be of a non-conducting material.

5. Lift the battery box vertically until it is separated from its seat in the tractor.

WARNING

The batteries which have reached the end of their operative live should be discarded of according to what is indicated in the regulations of each country.

6. Move the battery box laterally and lower it with care until it is placed on the ground.

To assemble, work in the inverse order

WARNING

Take care during the disassembly and assembly operations so as not to damage the battery, the feeding cable, the protecting roof or the battery closing cover.

PRECAUTIONS WITH THE BATTERY IN CASE OF EXTREME TEMPERATURES

Freezing point of the electrolyte in cold weather

Do not leave the battery too long unloaded before charging it, as with low charge the electrolyte density lowers, increasing its freezing possibility.

Electrolyte level in hot weather.

Verify the electrolyte level of the battery frequently, as an abnormal decrease can occur due to evaporation.

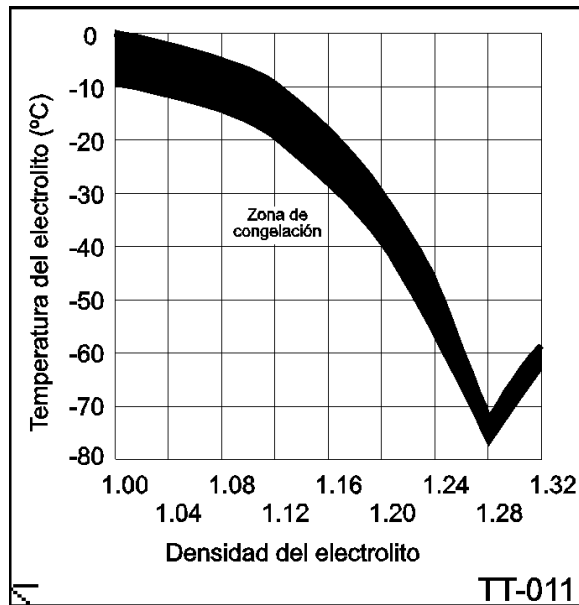

Wheels

WHEEL SUBSTITUTION

Rear driving wheels

WARNING

To be able to disassemble the wheels previous experience is needed. If necessary, get in touch with a CLARK concessionaire.

1. Park the tractor on a firm and levelled surface.
2. Disconnect the contact key.
3. Place wedges behind the front wheels so as to avoid any tractor movement.
4. Loosen the wheel nuts one or two turns, turning them anticlockwise.

WARNING

Do not take away the nuts until the wheels are lifted off the ground.

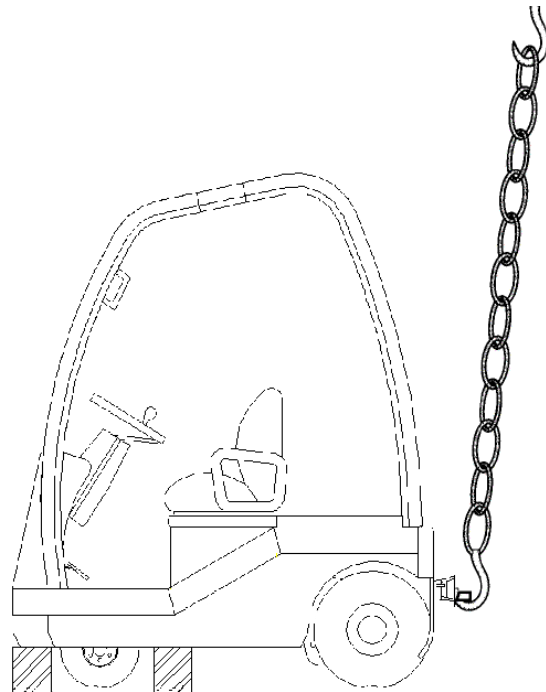

5. Hold the tractor by placing a wooden block under the front part of the frame.
6. Loosen the nuts completely and change the wheels.

WARNING

Be sure that the wooden blocks used to hold the tractor are solid and in one only piece.

7. Install back the wheel nuts, with an initial tightening.
8. Take away the wooden blocks you had placed under the frame.
9. Lower the tractor slowly and take away the wedges from the front wheels.
10. Finish the wheel nut tightening, applying the specified torque.
11. After some hours of operation, tighten the nuts again.

Front wheels

WARNING

To be able to disassemble the wheels you need previous experience. If needed, get in touch with a CLARK concessionaire.

1. Park the tractor on a firm and levelled surface.
2. Put on the parking brake and place wedges before the rear wheels so as to avoid any tractor movement.
3. Fasten the front of the tractor with a lifting sling, assuring that the total lifting capacity of the tackle is at least 2/3 of the tractor weight.
4. Loosen the wheel bushing nut, extracting the bushing and the wheel.

WARNING

Do not take away the nuts until the tractor is lifted off the ground.

5. Lift the tractor slowly with the tackle until the front wheels remain suspended. Place wooden blocks at each rear side of the frame.

WARNING

Be sure that the wooden blocks used to hold the tractor are solid and in one only piece.

7. Install the bushings again with the wheel mounted.
8. Take away the wooden blocks you had placed under the frame.
9. After some hours of operation, tighten the nuts again.

7. EXTENDED STORAGE

Place the tractor on a horizontal ground.

Disassemble the battery of the tractor and store it in a fresh dry place.

Wedge the tractor with wooden blocks, so that the tyres do not suffer any permanent distortion because they have to support its weight.

STORAGE FOR A LONG TIME

When the tractor is not going to be used for a long time, take the following measures and store it in a clean dry place.

WARNING

When the tractor cannot be stored inside, park it on a levelled area and cover it with a watertight protecting cover.

When storing it for a long time, be sure to consult the nearest CLARK concessionaire.

WARNING

Do not use a watertight cover or cover made of vinyl which tends to produce static electricity which could inflame the gas produced by the battery.

SERVICES PREVIOUS TO THE STORAGE

1. Lubricate the tractor according to the "lubrication programme". Apply corrosion resistant grease to all the exposed areas.
2. Charge the battery. Open the upper panel and disconnect the battery connector. Keep it in a secure, dry, ventilated place.

TRACTOR SERVICE DURING THE STORAGE PERIOD

1. Inspect the specific weight and the level of the battery electrolyte regularly. Charge and fill up with electrolyte whenever this is necessary. Carry out an equalling charge of the battery every two months.
2. Inspect the several tractor sections to see if there are stains or corrosion.
Clean the dirty areas and apply an anti-corrosive solution.



AFTER STORAGE SERVICES

1. Take away the corrosion resistant grease from the exposed areas.
2. Lubricate the indicated points.
3. Inspect the electrolyte level of the battery and the specific weight. Charge the battery completely.

4. Put the start up key into the position "I" to verify the meters, the warning lights and the indicators.
5. Follow with the "Functional testing".

8. TABLE OF THE CHARGES AND TECHNICAL SPECIFICATIONS

On this plate, situated on the battery protecting plate, the necessary information referring to weights, fittings, frame number, etc... are indicated.

CLARK				
MODEL			TYPE	
CHASSIS Nº			YEAR C.	
NOMINAL CAPACITY		Kg	VOLTAGE	V
FITTINGS				
WEIGHT BATTERY	MAX	Kg	MIN	Kg
WEIGHT FRAME WITHOUT BATTERY				
MAX. DRAW-BAR PULL				
NOM. DRAW-BAR PULL				
<p>Pol. Ind. Arazuri-Orcogen, Calle C, nº5-7, 31160 Arazuri Orcogen -NAVARRA- ESPAÑA. Telf. 0034-948324660 Fax. 0034-948324404 email: tecna2000@tecna2000.com www.tecna2000.com</p>				
PRODUCED BY TECNA 2000 CARRETILLAS, S.L.				

WARNING

Never surpass, in any case, the parameters referring to the hauling capacities, indicated on the plate.

Identification

SERIES NUMBER OF THE FRAME

The number is engraved on the flywheel support.

Specifications

FUSES

Traction circuit fuse: 8A
Auxiliary circuit fuse: 8A

CLARK®		TECHNICAL CHARACTERISTICS TRACTOR CTE-7 CTE-12 CTE-20				
Denomination	1	Manufacturer	Abbreviated denomination	CLARK	CLARK	CLARK
	2	Type	Denomination of the manufacturer	CTE-7	CTE-12	CTE-20
	3	Charging capacity	Nominal charge (without trailer)	7.000 Kg	12.000 Kg	20.000 Kg
	4	Hauling capacity	Hauling strength (tractor)	2.500 Nw	4.500 Nw	5.500 Nw
	5	Traction system	Electr., Diesel, Petrol, GLP, Battery	Battery	Battery	Battery
	6	Driving system	Sitting, standing, companion	Sitting	Sitting	Sitting
	7	Tyres	N= Tyres, SE= Super elastic	SE	SE	SE
	8	Wheels	Amount front/rear (X=driven)	2/2x	2/2x	2/2x
Dimensions	9	Platform area	Length x width platform	---	---	---
	10	Charging height		---	---	---
	11	Dimensions	Length	1600	1989	1989
	12		Width	970	1130	1130
	13		Height seat	860	949	949
	14		Height cabin roof	1970	1988	1988
	15	Turning radius	Outside	1545	1978	1978
	16		With the outer wheel	1248	1806	1806
	17		Inside	---	---	---
	18	Corridor width	90° turning	1675	1755	1755
	19	Overhanging	Rear	---	---	---
	20	Hooking height		277/331	277/331	277/331
Perform	21	Speed	With/without nom load nom. hauling strength	8/14	12/25	10/28
	22	Max. bar traction	With/without nominal load	4500 Nw	9000 Nw	11000 Nw
	23	Surpassable slope	With/without nominal load See diagram	%	%	%
	24	Max. surpassable slope	With/without nominal load See diagram	%	%	%
Weight	25	Own weight	Battery included	1272 Kg	1800 Kg	2200 Kg
	26	Charge on the shafts	With nom. load front/rear (trailer)	---	---	---
	27		Without load front/rear	---	880 / 920	1.030 / 1.170
Chassis	28	Wheels	Amount front/rear	2/2	2/2	2/2
	29		Front dimensions	4.00-4	16x6-8	16x6-8
	30		Rear dimensions	18x7-8	21x8-9	21x8-9
	31	Distance between axles		1040	1360	1360
	32	Gage	Centre of the front/rear wheel	146/790	822/940	822/940
	33	Franchise	With load minimum height	---	---	---
	34		With load between axles	---	---	---
	35	Service brake	Mechanic/hydraulic/electric/pneumatic	Hydraulic	Hydraulic	Hydraulic
	36		Amount of shafts, braking	1	1	2
	37	Parking brake	Pedal/manual/dead man	Manual	Manual	Manual
38	Damping		Yes	Yes	Yes	
Operation	39	Battery	According to DIN 43535/36 A/B/C NO	48 V	80 V	80 V
	40		Volt/capac. A 5 hours discharge	285 AH	480 Ah	480 Ah
	41		Weight	512 Kg	1250 Kg	1250 Kg
	42	Electric engines	Engine traction, nom power (TC 60 min)	2 x 2,5 Kw	2 x 4 Kw	2 x 5,5 Kw
	43		Lifting engine nom power (TC 15%)	---	---	---
	49	Connection	Frequency variation device	Alternat C.	Alternat C.	Alternat C.
52	Hooking	Type	Pin	Pin	Pin	

