

# CLARK<sup>®</sup>

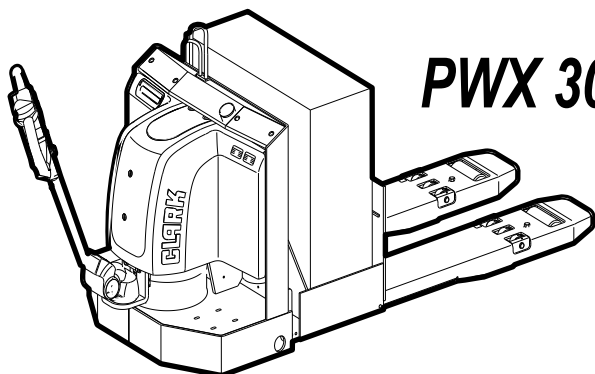

**PWX 30-40**

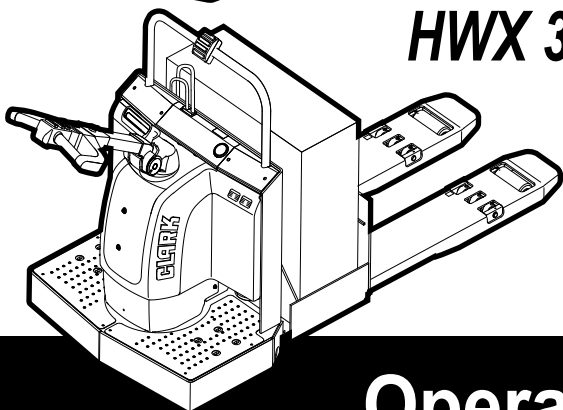

**HWX 30-40**

## Operator's Manual

Part No. 3344040  
OM - 878 (Rev 1.1)  
Jun. 2012

Do not remove this manual  
from the truck.

*Record the following information pertaining to your truck.*

Model No. \_\_\_\_\_

Serial No. \_\_\_\_\_

Customer Truck Identification No. \_\_\_\_\_

Truck Weight, Empty \_\_\_\_\_

Truck Rated Capacity \_\_\_\_\_

Truck Gross Weight \_\_\_\_\_

Truck Gross Weight, Loaded w/Rated Load \_\_\_\_\_

Special Equipment or Attachments \_\_\_\_\_

### **IMPORTANT**

**Do not expose this manual to hot water or steam.**

**The following warnings are provided pursuant to  
California Health & Safety Code Sections 25249.5 et. seq:**

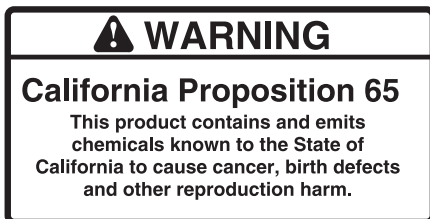

# Introduction

**Welcome** to the growing group of professionals who own, operate, and maintain CLARK lift trucks. We take pride in the long tradition of quality products and superior value that the CLARK name represents. This manual will familiarize you with the safety, operation, and maintenance aspects of your lift truck.

## Contents

The general topics covered in this manual are shown below. Detailed tables of contents are given at the beginning of each Section.

Before You Operate Your Lift Truck.....	ii
About this Manual .....	iv
Safety Signs and Safety Messages .....	vi
Truck Application .....	vii
Section 1. General Safety Rules.....	1-1
Section 2. Operating Hazards.....	2-1
Section 3. Know Your Truck .....	3-1
Section 4. Operating Procedures.....	4-1
Section 5. Daily Safety Inspection .....	5-1
Section 6. Planned Maintenance .....	6-1
Section 7. Towing .....	7-1
Section 8. Specifications.....	8-1
Index .....	Index-1



# Before You Operate Your Lift Truck

You must be trained and authorized to operate a lift truck.

## LEARN TO PREVENT ACCIDENTS

First: Learn safe operating rules and your company rules.

Next: Read your Operator's Manual. If you do not understand it, ask your supervisor for help.



Learn about the unit you operate.



## KNOW YOUR TRUCK

Then: Practice operating your truck safely.

And: Keep your truck in safe operating condition with correct and timely maintenance.

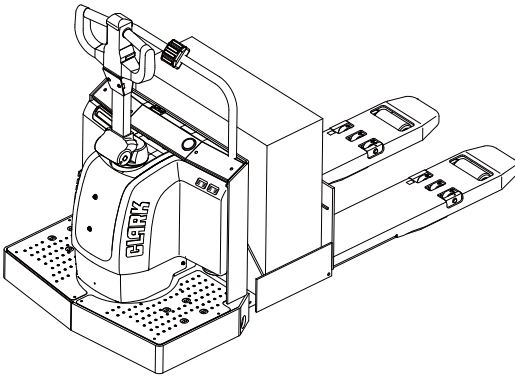

**Breaking these rules will cause serious or fatal injury to yourself and others.**



# Before You Operate Your Lift Truck

## ...Be Prepared

Lift trucks are specialized machines with unique operating characteristics. They require specific instructions and rules for safe operation and maintenance. CLARK lift trucks are built to take hard work, but not abuse. They are built to be dependable, but they are only as safe and efficient as the operator and the persons responsible for maintaining them.

## Safety Standards

Your CLARK lift truck is designed and built to be as safe and efficient as today's technology can make it. As manufactured, it meets all the applicable mandatory requirements of ANSI B56.1 Safety Standard for Powered Industrial Trucks. In addition, all standard trucks conform to Underwriters Laboratories requirements for the type designation shown on the truck capacity plate. Each truck is also furnished with certain safety devices—horn, for example—as standard equipment.

ANSI B56.1, the standard for lift truck operation, includes rules about operation, selection, training, supervision, and maintenance. We suggest that owners, operators, and supervisors read this standard. See “Safety Standards” in Section 6 for more information.

## Safe Operation

Safe operation of lift trucks is of primary importance to CLARK. Our experience with lift truck accidents has shown that when accidents happen and people are killed or injured, the causes are:

- **Operator is not properly trained**
- **Operator is not experienced with lift truck operation**
- **Basic safety rules are not followed**
- **Lift truck is not maintained in safe operating condition.**

For these reasons, CLARK wants you to know about the safe operation and correct maintenance of your lift truck. Clark provides this *Operator's Manual* to help.

This manual is not a training manual, however. It is a guide to help trained and authorized operators safely operate their lift trucks. It



emphasizes and illustrates the correct procedures, but it cannot cover every possible situation which may result in an accident. You must watch for all hazards in your work areas and avoid or correct them. While it is important that you know and understand the information in this manual, you must also know and follow your company safety rules! Be sure that your equipment is maintained in a safe condition. Do not operate a damaged truck. Practice safe operation every time you use your lift truck.

Remember, before you start operating this lift truck, be sure that you understand all operating procedures. It is your responsibility, and it is important to you and your family, to operate your lift truck safely and efficiently. Be aware that the Federal Occupational Safety and Health Act (OSHA) and state laws require that operators be completely trained in the safe operation of lift trucks. If you think you need training, ask your supervisor.

### **Safety and Planned Maintenance**

Regular maintenance and care of your lift truck is essential for your safety. A faulty lift truck is a potential source of danger to the operator, and to other personnel working near it. Proper maintenance is also important for economy and utilization. As with all quality equipment, keep your lift truck in good operating condition by following the recommended schedule of maintenance.

A lift truck should be examined by the user on a daily basis to be sure it is safe to operate. Do not make any repairs to this truck unless you have been trained in safe lift truck repair procedures and are authorized by your employer.

In addition to the daily user inspection, CLARK recommends that a planned maintenance and safety inspection program (PM) be performed by trained and authorized personnel. Inspections, adjustments, and repairs done during the PM increase the life of components and reduce unscheduled downtime. The PM can be scheduled to meet your particular application and lift truck usage.

Your CLARK dealer is prepared to help you implement a PM program with trained service personnel who know your lift truck and can keep it operating safely and efficiently.



## About this Manual

To operate a truck safely and productively, the operator must know and understand the appropriate safety practices, including safe operating and load handling techniques. To develop the skill required, the operator must become familiar with the construction and features of the lift truck. The operator must also understand the capabilities and limitations of the lift truck and see that it is kept in a safe condition.

This manual is a digest of essential information on the above subjects.

The information is provided in eight Sections:

**Section 1, General Safety Rules**, reviews and illustrates accepted practices for safe operation of a lift truck.

**Section 2, Operating Hazards**, warns of conditions that could cause damage to the truck or injury to the operator or other personnel.

**Section 3, Know Your Truck**, describes the major operating components, systems, controls, and other features of your truck.

**Section 4, Operating Procedures**, presents specific instructions on the safe, efficient operation of your lift truck.

**Section 5, Daily Inspection**, explains how to perform the operator's daily safety inspection.

**Section 6, Planned Maintenance**, serves as reference for trained service personnel performing planned maintenance and battery maintenance.

**Section 7, Towing**, presents procedures for towing.

**Section 8, Specifications**, provides reference information on features, components, and maintenance items.

Also, the **Index** helps you locate information about various topics.



## NOTICE

**The descriptions and specifications in this manual were in effect at the time of printing. CLARK Material Handling reserves the right to make improvements and changes in specifications or design, without notice and without incurring obligation. Check with your authorized CLARK dealer for information on possible updates or revisions.**

We urge you to carefully read this manual from cover to cover. Take time to understand the information on general safety rules, operating hazards, and operating procedures. Understand how all gauges, indicator lights, and controls function.

This manual is permanently attached to your lift truck to serve as a reference for anyone who may operate or service it. If the truck is not equipped with this manual, ask your supervisor to obtain one and have it attached to the truck. And remember, your CLARK dealer is pleased to answer questions about the operation and maintenance of your lift truck and will provide you with additional information should you require it.

For detailed service information, refer to the *Service Manual*.





## Safety Signs and Safety Messages

Improper operation can cause accidents. Don't take chances with incorrect or damaged equipment. **Read** and **understand** the procedures for safe driving and maintenance outlined in this manual. Don't hesitate to ask for help. **Stay alert!** Follow safety rules, regulations, and procedures. Avoid accidents by recognizing dangerous procedures or situations before they occur. **Drive and work safely** and follow the safety signs and their messages on the truck and in this manual.

**Safety signs and messages** are placed in this manual and on the truck to provide instructions and identify specific areas where potential hazards exist and special precautions should be taken. Know and understand the meaning of these instructions, signs, and messages. Damage to the truck, death, or serious injury to you or other persons may result if these messages are not followed. If warning decals are damaged, they must be replaced. Contact your CLARK dealer for replacements.

### NOTICE

**This message is used when special information, instructions or identification is required relating to procedures, equipment, tools, pressures, capacities and other special data.**

### IMPORTANT

**This message is used when special precautions should be taken to ensure a correct action or to avoid damage to or malfunction of the truck or a component.**



### CAUTION

**This message is a reminder of safety practices that can result in personal injury if proper precautions are not taken.**



### WARNING

**This message indicates a hazard exists that can result in injury or death if proper precautions are not taken.**



### DANGER

**This message is used when an extreme hazard exists.**

## Truck Application

Each model is designed for a specific set of work tasks and conditions.

Be sure you are using the right truck for the job.

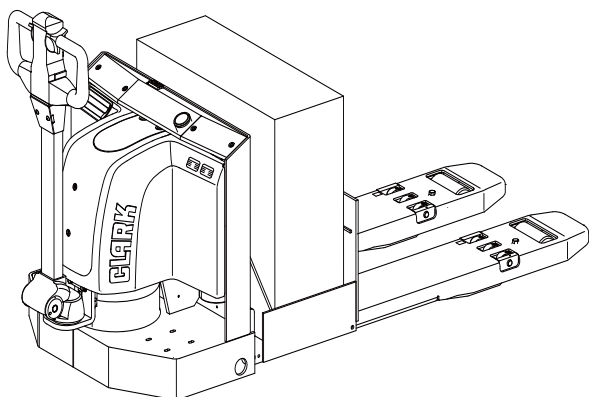

**PWX model** lift trucks are designed for moving loads short distances.

No riding is allowed on P model trucks.

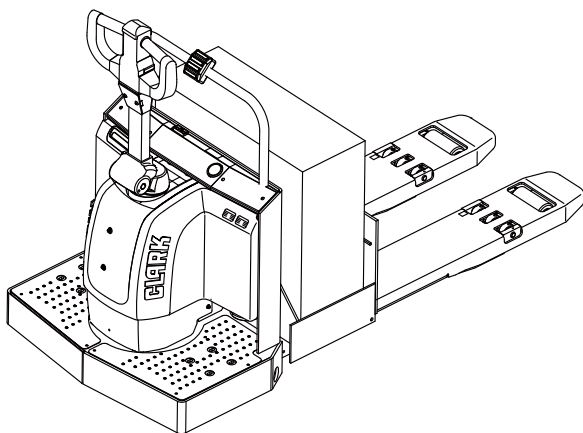

**HWX model** lift trucks are designed for moving loads longer distances.

Operators can walk with the truck or ride using the hand rail.

# General Safety Rules

## Contents

Do's and Don'ts.....	1.2
No Riders .....	1.3
Pedestrians.....	1.4
Grades .....	1.5
Travel .....	1.6
Pinch points .....	1.7
Parking.....	1.8



## Do's and Don'ts



CM0001

**Don't mix drugs or alcohol with your job.**

**Do watch for pedestrians.**



CM0002



**Don't block safety, or emergency equipment.**

**Do wear required safety when equipment.**



CM0004



CM0005

**Don't smoke in "NO SMOKING" areas or when recharging.**

## No Riders



Always walk with PWX model trucks. Never attempt to ride.



The operator must be the only rider on HWX model trucks.

# Pedestrians

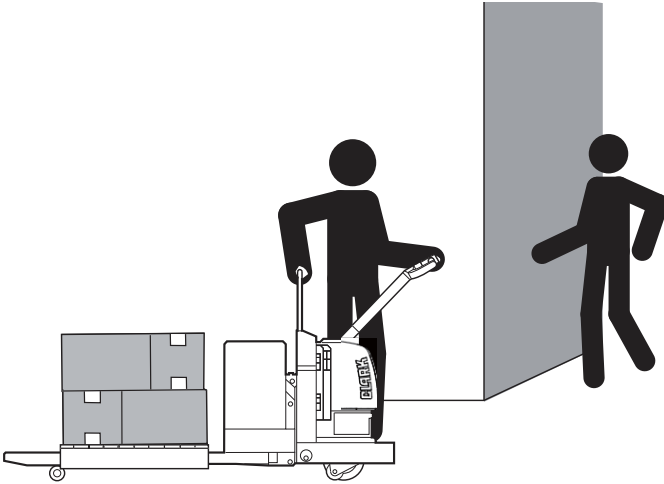

Watch where you are going. Pedestrians may use the same roadway you do. Sound your horn at all intersections.

Watch for people in your work area. They may not watch for you.

## Grades

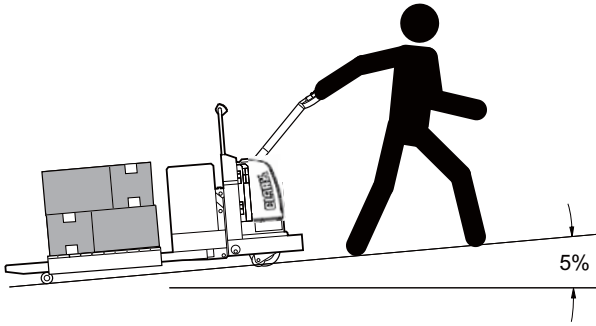

Always keep forks downgrade with or without a load and in the raised position when working on a grade. Do not ride HWX model on a grade.

Trucks are designed to travel up a 5 % maximum grade with load.

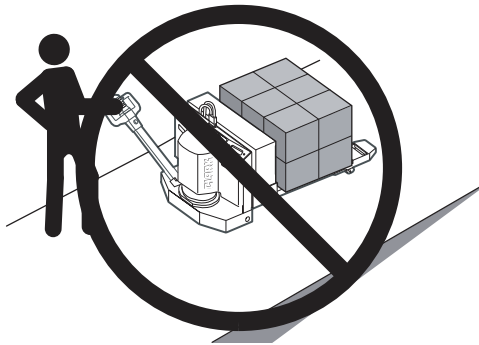

**WARNING**

**Never turn on a grade, either loaded or unloaded.**

## Travel

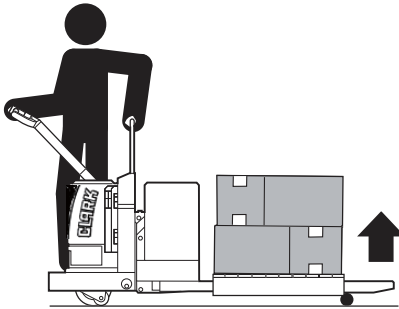

Always carry loads in the raised position.

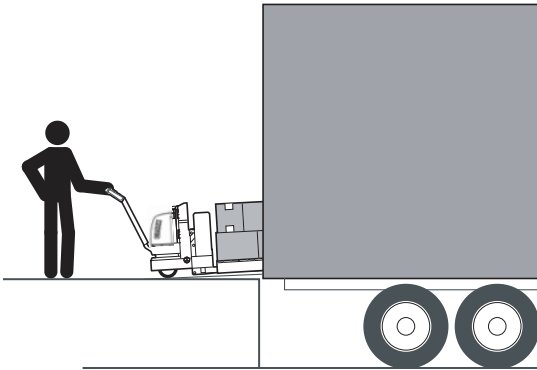

Enter confined areas such as semi-trailers, trucks, boxcars or elevators with load end of your truck first. This will minimize the maneuvering necessary to exit. If load blocks your view while traveling in reverse, make sure path is clear of personnel and obstructions.

### CAUTION

**Always take extra care in any confined places. Think ahead of your moves. When moving in and out of confined space allow enough room for yourself between the truck and walls, racks, pallets etc.**



## Pinch Points

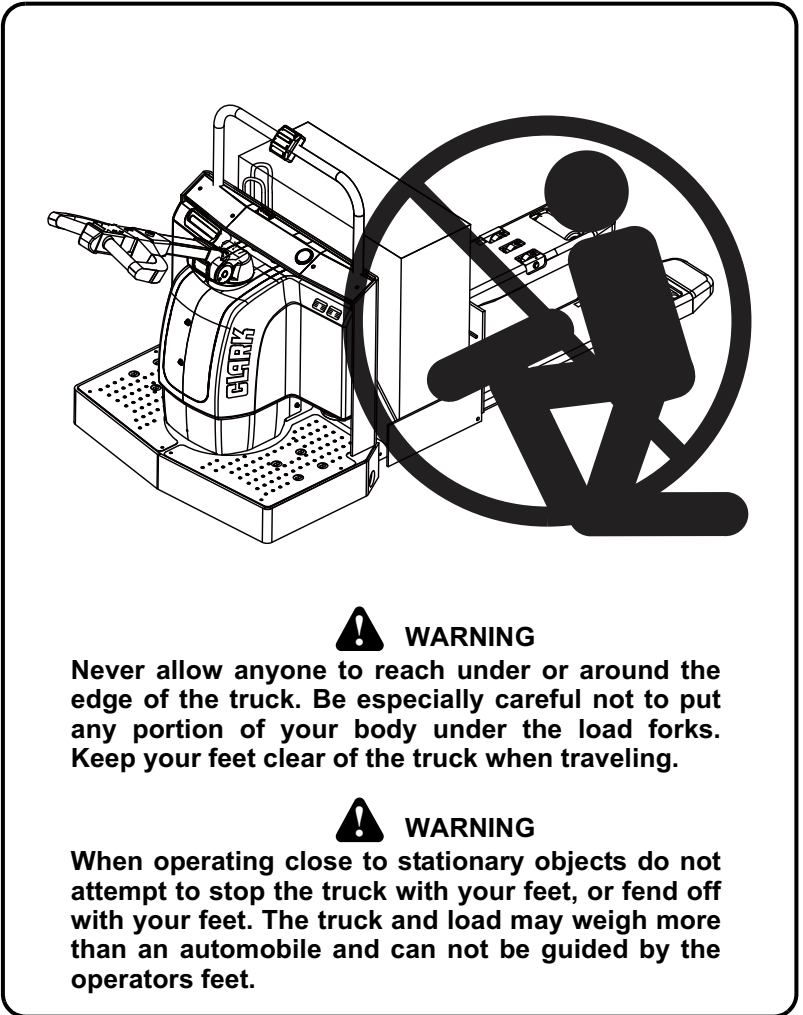

### WARNING

Never allow anyone to reach under or around the edge of the truck. Be especially careful not to put any portion of your body under the load forks. Keep your feet clear of the truck when traveling.



### WARNING

When operating close to stationary objects do not attempt to stop the truck with your feet, or fend off with your feet. The truck and load may weigh more than an automobile and can not be guided by the operators feet.

## Parking

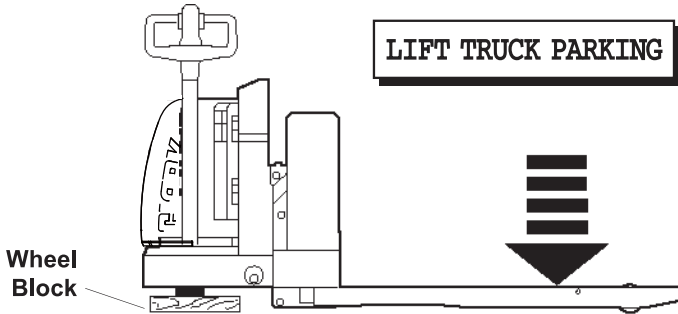

Park trucks in designated parking areas only. Do not obstruct traffic lanes or aisles. Lower forks to floor. Place control handle in full turn and raise handle to "up" position to apply brake. Turn key switch off and remove key. Unplug battery connector. Block drive wheel to prevent accidental roll. Turn key in to proper authority.

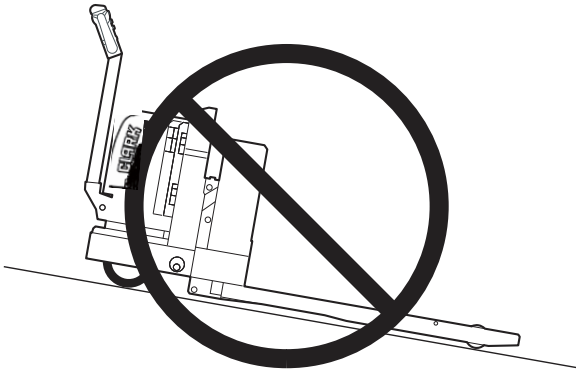

 **WARNING**  
Never park on a grade.

# Operating Hazards

## Contents

Fast Turns.....	2.2
Corner Cutting.....	2.2
Loose Loads.....	2.3
Long and Wide Loads.....	2.3
Dock or Trailer Drop offs.....	2.4
Trailer Creep.....	2.4
Debris on Floor .....	2.5
Damaged Pallets and Skids .....	2.6

### IMPORTANT

The operation of lift trucks involves many hazardous situations. This section describes some of the more common ones. Your place of work may have hazards not described. Be alert to those situations that can result in injury and possibly death.



## Fast Turns • Corner Cutting

### Fast Turns

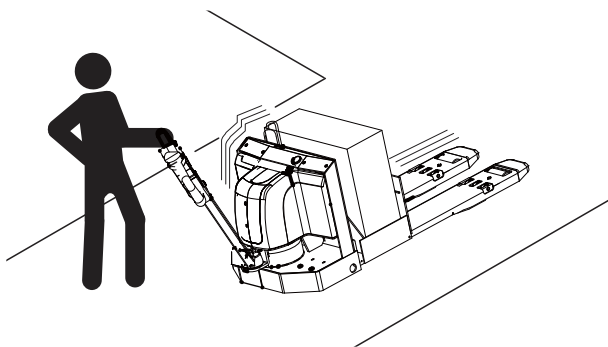

### WARNING

Slow down on turns. An empty truck can tip over easier than a loaded truck.

### Corner-Cutting

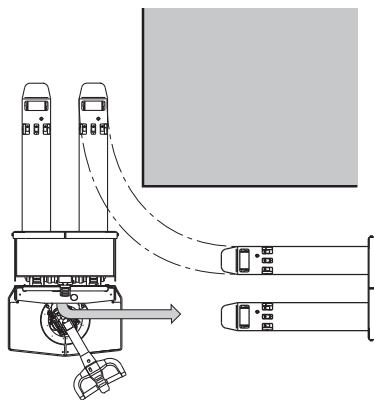

### WARNING

Always use caution when making a turn into an aisle. The load wheels do not follow the turn path of the drive wheel and will tend to "cut" the corner.

## Loose Loads • Long or Wide Loads

### Loose Loads

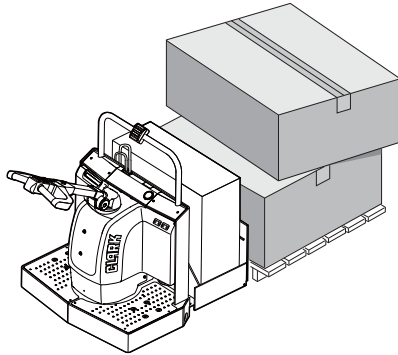

#### WARNING

Falling loads can seriously injure yourself or others. Never carry uneven material. Stack loose material evenly.

### Long or Wide Loads

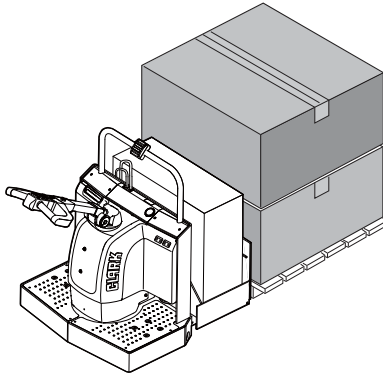

#### WARNING

Long or wide loads are less stable and may strike objects or persons in their path. Watch load clearance, move slowly and turn carefully.

## Drop Offs • Trailer Creep

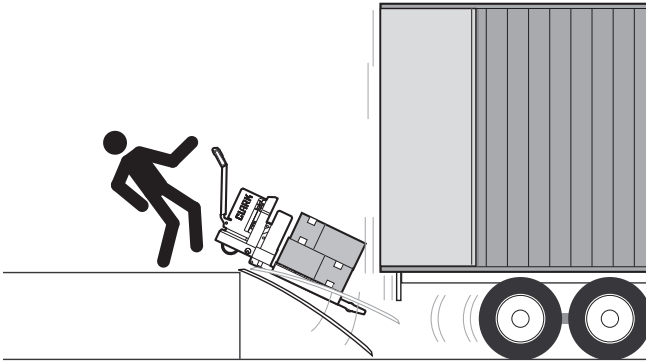

### WARNING

Talk to the truck driver yourself and make sure he does not move the trailer until you are done! Make sure the driver applies the trailer brakes and chocks trailer wheels. The impact of moving in and out of a trailer may cause the trailer to move.

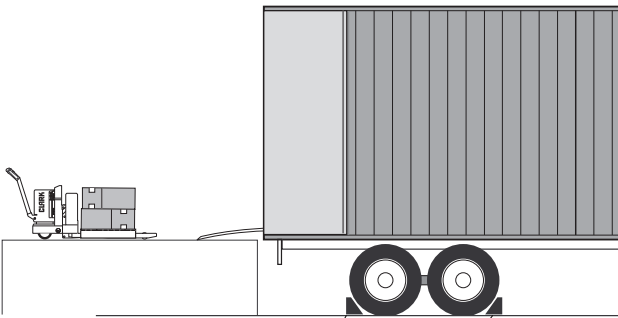

Wheel Chocks

### IMPORTANT

Use wheel chocks. Use trailer-to-dock locking systems, if available.

## Debris on Floor

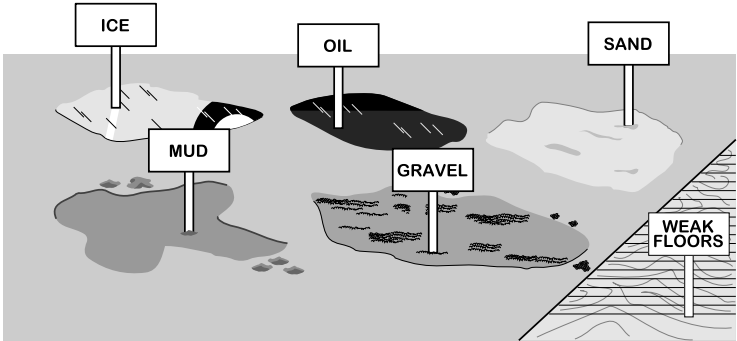

### WARNING

Oil, water, sand, mud, wood, gravel and other materials will make the floor slippery, uneven and dangerous. Be careful when crossing these areas.



### WARNING

Know the weight of your truck and load. Especially when using elevators. Know the capacity of the elevator you intend to use. Do not overload.

## Damaged Pallets and Skids

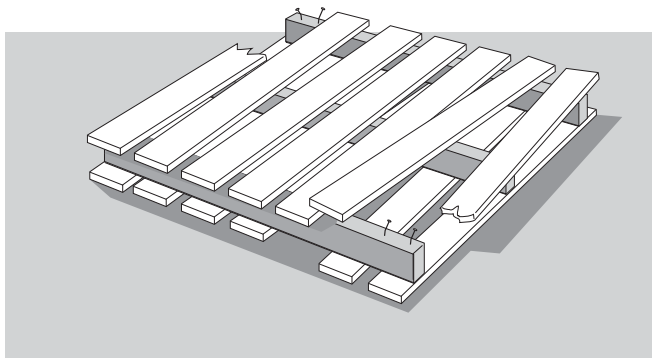

### **WARNING**

**Do not move or store materials on damaged or poorly maintained pallets and skids. Items can fall through or off them causing severe injury or death.**



# Know Your Truck

## Contents

Component Location (PWX Model) .....	3.2
Component Location (HWX Model).....	3.3
Operator's Controls (PWX Model) .....	3.4
Operator's Controls (HWX Model).....	3.5
Maintenance Component Location (PWX Model)	3.6
Maintenance Component Location (HWX Model)	3.7
System Description .....	3.8
Nameplate Description .....	3.10
Warning Decals .....	3.11



## Component Location PWX

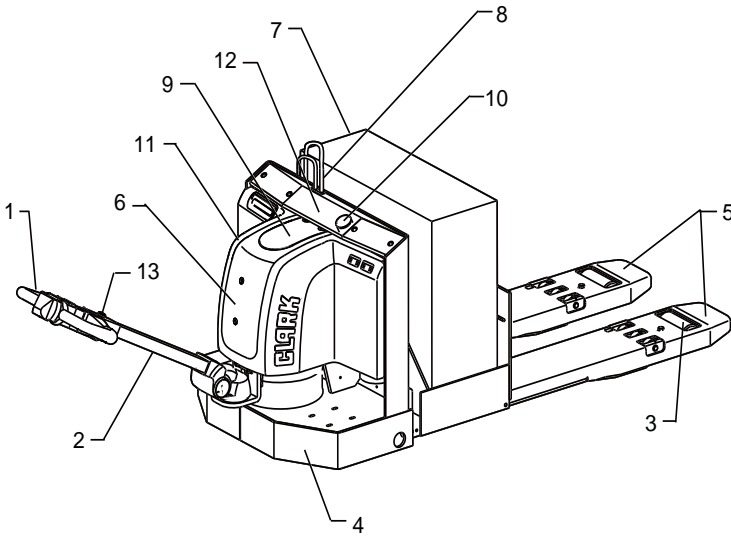

- |                                      |                                    |
|--------------------------------------|------------------------------------|
| 1. Steering and Brake Control Handle | 8. Battery Connector               |
| 2. Truck Data Plate                  | 9. Hour Meter (optional)           |
| 3. Load Wheels                       | 10. Hour Meter (optional location) |
| 4. Drive Wheel                       | 11. Operator's Manual              |
| 5. Load Forks                        | 12. Warning Decals                 |
| 6. Cover                             | 13. Key Switch                     |
| 7. Battery                           |                                    |

## Component Location HWX

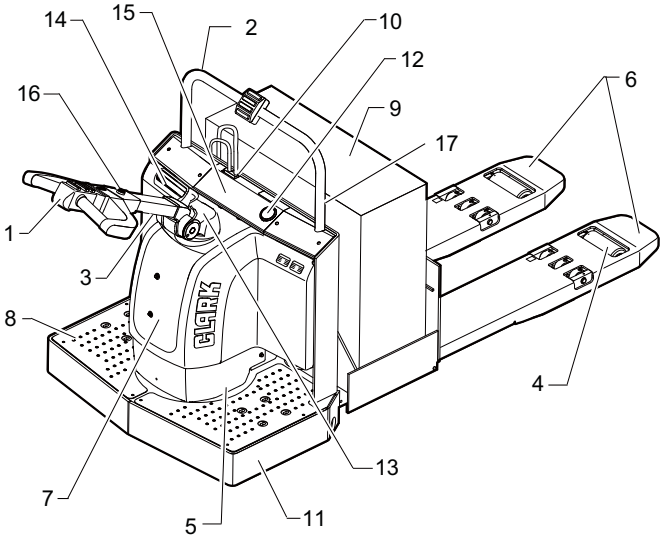

- |                                      |                                       |
|--------------------------------------|---------------------------------------|
| 1. Steering and Brake Control Handle | 9. Battery                            |
| 2. Operator Hand Rail                | 10. Battery Connector                 |
| 3. Truck Data Plate                  | 11. Stability Casters                 |
| 4. Load Wheels                       | 12. Hour Meter (option)               |
| 5. Drive Wheel                       | 13. Coast Control (option)            |
| 6. Load Forks                        | 14. Operator's Manual                 |
| 7. Cover                             | 15. Warning Decals                    |
| 8. Rider Platform                    | 16. Key Switch                        |
|                                      | 17. Optional Operator Manual Location |

## Operator's Controls PWX

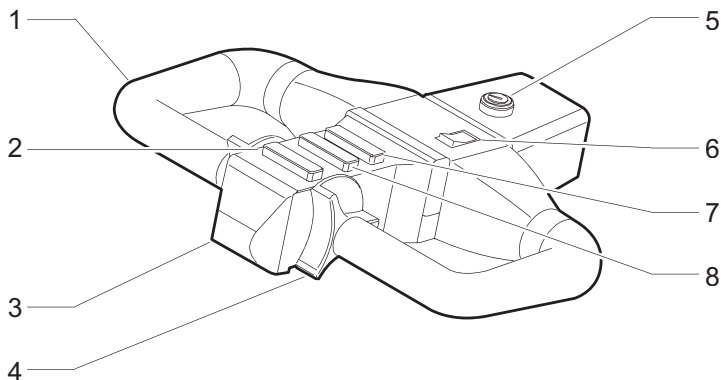

1. Steering and Brake Control Handle
2. Lift Control Button
3. Emergency Reversal Switch
4. Forward/Reverse Control (*Butterfly*)
5. Key Switch
6. Speed Control Switch
7. Horn Button
8. Lower Control Button

## Operator's Controls HWX

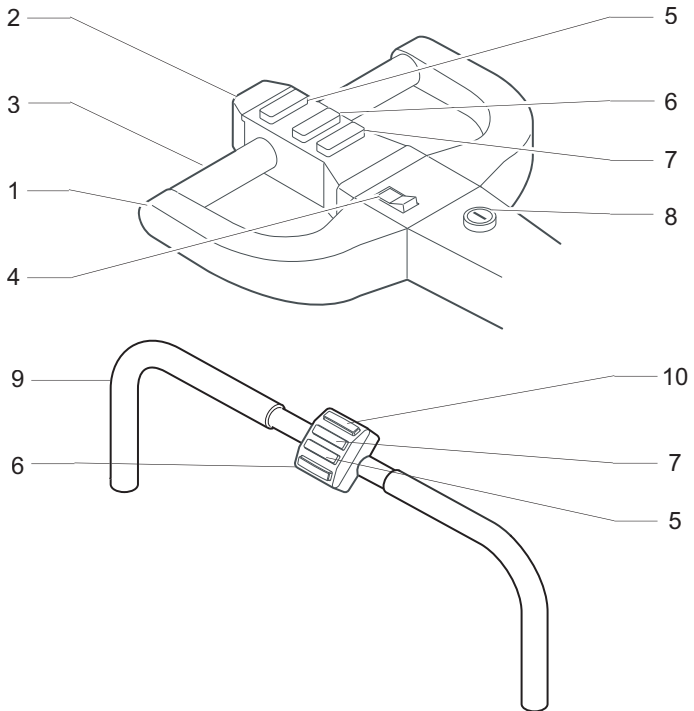

1. Steering and Brake Control Handle
2. Emergency Reversal Switch
3. Forward/Reverse Control (*Twist Grip*)
4. Speed Control Switch
5. Lift Control Button
6. Lower Control Button
7. Horn Button
8. Key Switch
9. Operator Grab Bar
10. Speed Button (Rabbit)

# Maintenance Component Location PWX

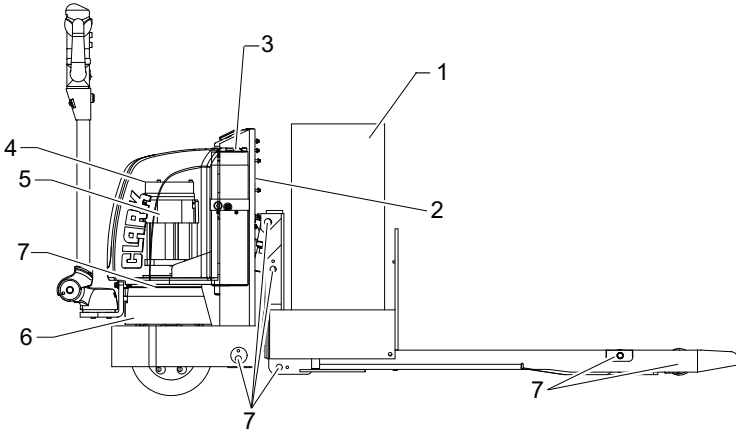

1. Battery
2. Traction Control Panel
3. Hydraulic Unit
4. Brake
5. Drive Motor
6. Drive Unit
7. Lubrication Fittings

## Maintenance Component Location HWX

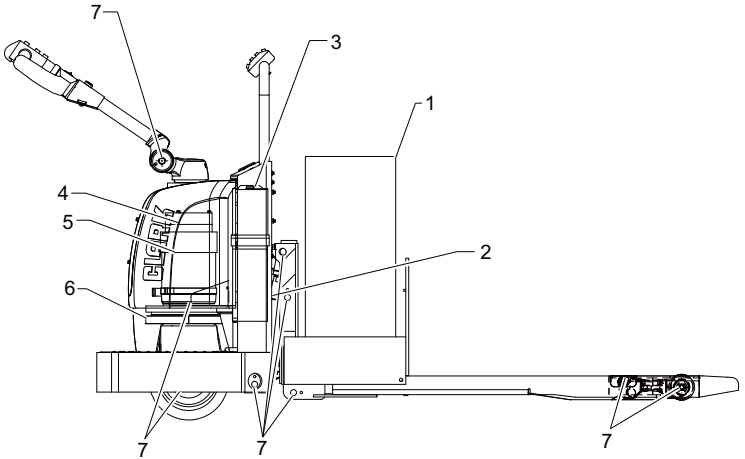

1. Battery
2. Traction Control Panel
3. Hydraulic Unit
4. Brake
5. Drive Motor
6. Drive Unit
7. Lubrication Fittings

# System Description

## Control Handle

- Controls travel direction and speed, lift and lower, horn, braking and steering.
- Twist grip or butterfly type speed control for left or right hand operation.
- Up or down brake application.
- Safety reversing switch on end of control handle.
- 180° rotation for maneuverability.
- Coast control (optional HWX model).
- Order picking (optional HWX model).

## Operator Hand Rail (HWX models)

- Provides control of lift, lower, horn and high speed travel functions.

## Drive Unit

- Double reduction helical spur and spiral bevel gears
- Totally enclosed with lubricating oil bath
- Vertical mount drive motor
- Five bolt drive wheel mounting for simple removal and replacement.

## Brake

- Double acting.
- Electromagnetic type brake.
- Easy service accessibility.

## Electrical

- 24 volt electrical system
- U.L. listed, type "E"
- Inverter type control features cool and quiet operation, cold switching for increased contactor tip life, and infinitely variable travel speed control.
- Drive motor features class "F" insulation(induction motor) and hydraulic motor features class "H" insulation, both are vertically mounted for easy service accessibility.



### Hydraulic system

- Integral motor - pump - reservoir assembly features a control valve and pressure relief valve for controlled lowering and system overload protection.
- Closed system reduces contamination.
- Piston type lift cylinder is vertically mounted and provides for fork heel adjustment.

### Frame and Forks

- Formed steel plate with bar steel reinforcements.
- Square section solid steel pull rods.
- Elevating bracket with three lug mounting design.
- Lift linkage easily greasable at all pivot points.
- Lift linkage provides 6" of lift.
- Spring loaded stability casters (standard equipment on HWX models)

### Standard Equipment

Standard features include: ZAPI ACE2\_500Arms (HWX) or ACE2\_400Arms (PWX) Control System, ZAPI MDI-CAN display battery discharge indicator, full 6" lift height, horn, key switch, 24 volt electrical system, cushion rubber drive tire, poly load wheels, 7" or 13.6" wide battery compartments, SB-175 amp grey connector, high visibility Clark green and black finish. Additional HWX features include spring loaded stability casters, operator platform with non-skid metal surface, and operator hand rail with center mounted control buttons.

### Optional Equipment

Optional equipment includes: coast control (*HWX Only*), load backrests, polyurethane drive tire, battery compartment rollers and right hand exit gate, "EE" electrical system, cold storage protection, corrosion protection and dual load wheels. Fork options include 22" fork widths, 48", 60", 72" and 96" standard fork lengths, and first opening second pallet 84", 93", and 96" extended tip forks.

# Nameplate Description

**CLARK**

MODEL NUMBER

TYPE

SERIAL NUMBER

CAPACITY

LBS  IN

KG  MM

TRUCK WEIGHT  
WITHOUT BATTERY

WITH MAX BATTERY

BATTERY WEIGHT  
MAXIMUM

MINIMUM

BATTERY NUMBER

D C VOLTAGE

MAX AMP HOURS

FROM FACTORY THIS TRUCK MEETS  
PART II, ANSI B-56.1 1969/1988

## Know The Data On The Nameplate

1. Truck registered name.
2. Type of construction. The code number signifies the UL type of protection. Check with proper authority before entering areas where flammable or explosive material may be present.
3. Truck serial number.
4. Capacity, data.
5. Truck weight, less load.
6. Battery weight.
7. Battery identification number.
8. System voltage.
9. Battery ampere-hour rating.

### IMPORTANT

**When attachments are added or if the truck is modified, the capacity of the truck may be affected. Contact your authorized Clark dealer for a new nameplate showing the revised capacity.**

## Warning Decal

Here are examples of decals which give important information about operation and safety. OSHA and ANSI require you to replace them if they are missing or unreadable. Get familiar with them and follow the instructions. If you don't understand them, ask your supervisor for help.



### Operator Safety Warning Decal

The operator's warning decal describes basic instructions for safe operation of a lift truck. Read and understand these instructions and the other safety messages in this manual and on the lift truck.

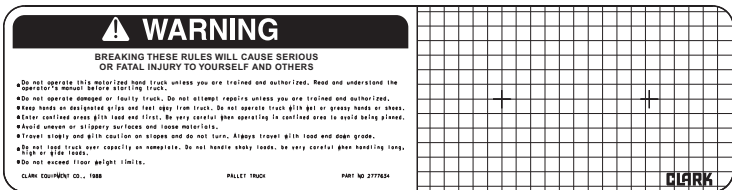

- Do not operate this motorized hand truck unless you are trained and authorized. Read and understand the operator's manual before starting truck.
- Do not operate damaged or faulty truck. Do not attempt repairs unless you are trained and authorized.
- Keep hands on designated grip and feet away from truck. Do not operate truck with wet or greasy hands or shoes.
- Enter confined areas with load and first. Be very careful when operating in confined area to avoid being pinned.
- Avoid uneven or slippery surfaces and loose materials.
- Travel slowly and with caution on slopes and do not turn. Always travel with load down grade.
- Do not load truck over capacity on nameplate. Do not handle shaky loads, be very careful when handling long, high and wide loads.
- Do not exceed floor weight limits.



### No Riding Decal

This safety decal is placed on the top cover to warn of the danger of injury by attempting to ride PWX model trucks. Always walk with PWX model truck.



### No Passenger Decal

This safety decal is placed on the top cover to warn of the danger of injury by attempting to ride as a passenger on HWX model trucks. The operator must be the only rider on HWX model trucks.



### Battery Warning Decal

This decal is located on the right cover to give warning to disconnect the battery before servicing and to maintain correct battery polarity.

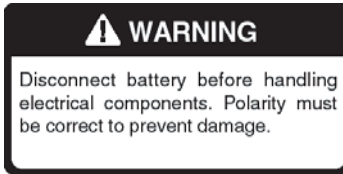

### Coast Control Decal

This decal is located on the control handle base cover to give warning when the brake is deactivated on the HWX model trucks equipped with the coast control option.



# Operating Procedures

## Contents

Beginning Truck Operation.....	4.2
Travel Control.....	4.3
Emergency Reversal Switch .....	4.4
Lift & Lower Control (PWX Model) .....	4.4
Lift & Lower Control (HWX Model) .....	4.5
Horn Control.....	4.6
Braking.....	4.7
Plugging.....	4.7
Load Handling .....	4.8
Coast Control (Option) .....	4.9
Parking.....	4.9



## Beginning Operation

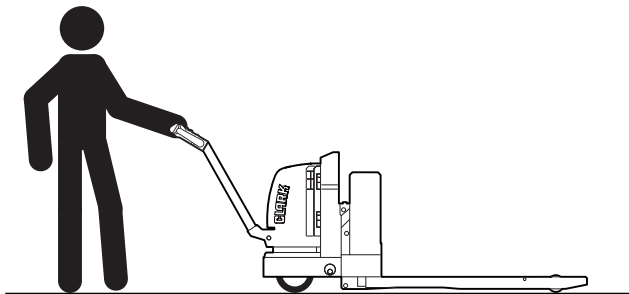

Remove chocks from drive wheel. Plug in battery connector. Lower control handle to comfortable operating position and swing handle in line with intended path of forward or reverse travel. Insert key and turn clockwise to "on" position. Check to make sure your path of travel is clear of people or obstructions.

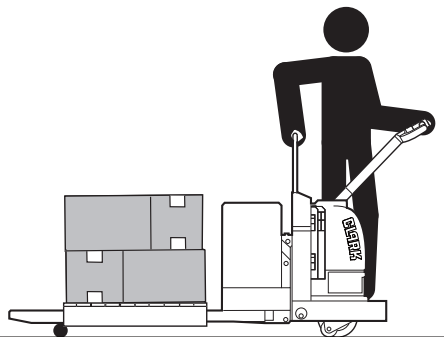

Make sure HWX model are completely stopped before you get on or off. Keep one hand on control handle and other hand on operator hand rail. Keep your feet back from edge of operator's platform while operating truck. Do not ride HWX model trucks while traveling on ramps, picking up or depositing loads, or maneuvering in close quarters.

## Travel Control

### PWX Travel Control

Rotate the direction/speed control as shown to travel forward. Rotate the direction/speed in the opposite direction to travel in reverse. ("Reverse" is defined as the direction in which the forks point.) Truck speed increases the further you rotate the direction/ speed control. When you release the control, it rotates back to the "neutral" position.

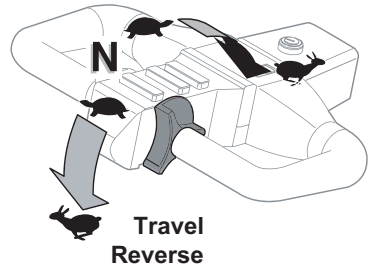

### HWX Travel Control

Rotate the direction/speed control as shown to travel forward. Rotate the direction/speed in the opposite direction to travel in reverse. ("Reverse" is defined as the direction in which the forks point.) Truck speed increases the further you rotate the direction/ speed control. When you release the control, it rotates back to the "neutral" position.

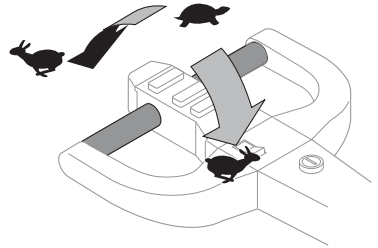

### HWX High Speed Control

When riding HWX model trucks for long distances, you can use the high-speed control on the operator hand rail to provide additional speed. Rotate the direction/ speed control fully to the maximum speed position, then press the high-speed control button. The truck goes into higher speed and stays there until the throttle returns to neutral.

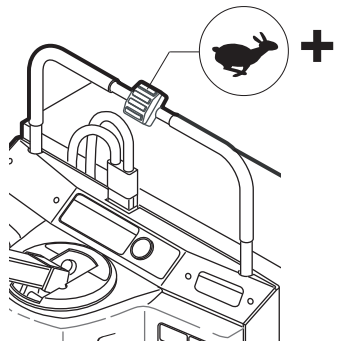

# Emergency Reversal Switch • Lift/Lower Control

## Emergency Reversal Switch

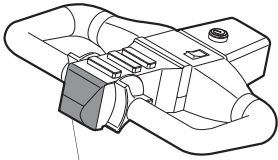

PWX

Emergency Reversal Switch

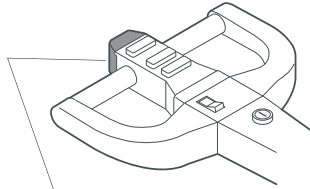

HWX

Emergency Reversal Switch

When the emergency reversal switch strikes an object or a person, or is held in by the operator, the truck automatically propels itself in the "reverse" direction. ("Reverse" is defined as the direction in which the forks point.) When the switch no longer contacts the person or object, the switch pops up and the truck resumes normal control. Emergency reversal is disabled when the brake is "on" or when the truck is in high speed "ride" mode.



### CAUTION

Be careful not to activate *Emergency Reversal Switch* when pulling down the handle from the parked position.

## Lift and Lower Control

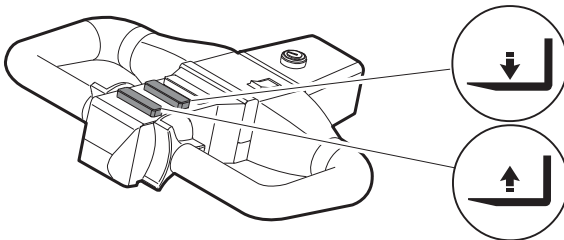

### PWX Lift /Lower Control

- Press the "lift" control to raise the load forks.
- Press the "lower" control to lower the load forks.



## Lift/Lower Control • Hand Rail

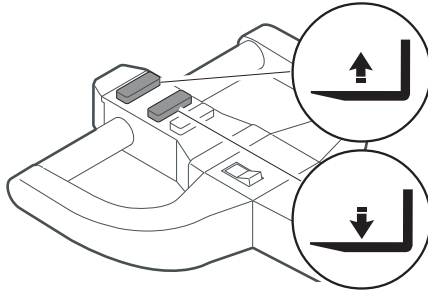

### HWX Lift /Lower Control

- Press the "lift" control to raise the load forks.
- Press the "lower" control to lower the load forks.

### Operator Hand Rail Lift and Lower Control (HWX Model)

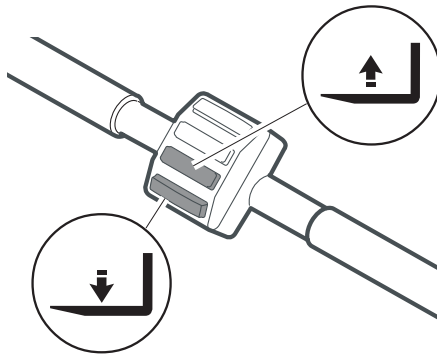

- Press the "lift" control to raise the load forks.
- Press the "lower" control to lower the load forks.

### IMPORTANT

Always travel with the load forks fully elevated to provide maximum floor clearance.

## Horn Button

### Horn Button

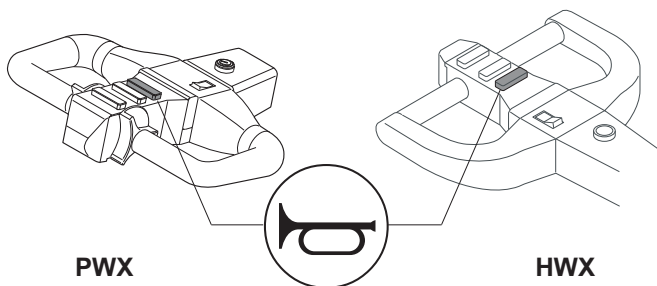

- Press either horn button to sound horn.

## Braking • Plugging

### Braking

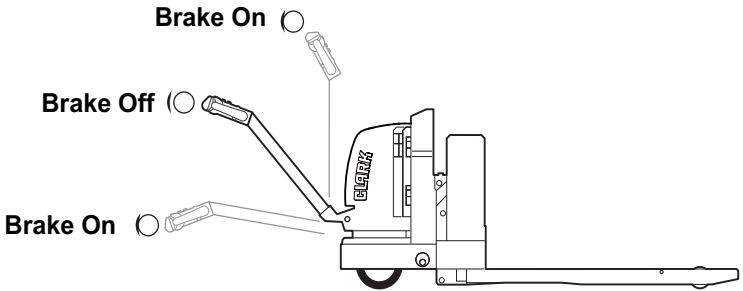

Lowering the control handle to the operating position disengages the brake. Pushing the control handle to the "up" position or pulling the control handle to the "down" position applies the brake and shuts off the drive motor.

To stop the truck during operation, release the travel control and apply the brake by pushing the control handle to the "up" position to bring the truck to a smooth stop.



### CAUTION

**When operating a HWX "rider" truck, always bring the truck to a complete stop before getting on or off.**

### Plugging (optional braking)

You can change direction and stop the truck without braking, by "plugging." As you are traveling, move the travel control to the opposite direction. The truck should slow to a smooth, controlled stop and then accelerate in the opposite direction.

You can control the plugging distance with the travel control (direction/ speed): The farther the direction speed control is rotated, the shorter the reversal distance.



### CAUTION

**Be careful when plugging. Any sudden change in direction can cause the load to move or fall off forks.**

## Load Handling

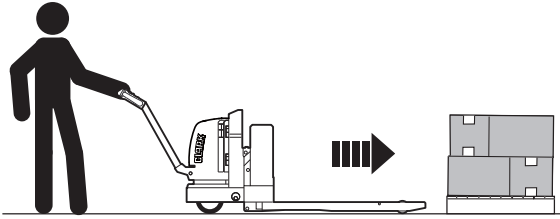

- Lower forks completely before entering load.
- Center forks with load as you approach.
- Enter load as far as possible.

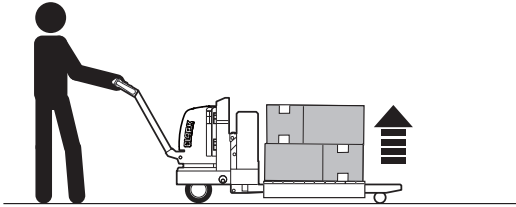

- Make sure the lifting area is clear before lifting load.
- Raise forks completely before moving truck.
- Avoid operating hazards and observe general safety rules while moving load.

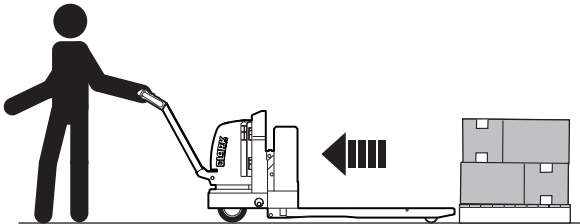

- Always approach load deposit areas squarely and cautiously.
- Be especially careful when placing loads near water pipes, electrical wiring or outlets, steam pipes, heaters, and other dangerous or fragile equipment.
- After placing load in position, lower the forks completely.
- Withdraw the forks squarely from the load.

## Parking

### Optional Coast Control (HWX Models)

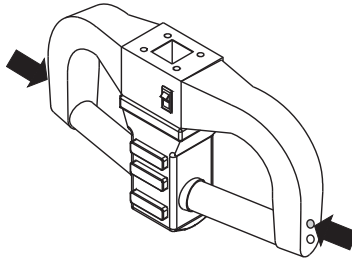

The coast control deactivates the brake and enables the truck to be "jogged" with the travel control and coasted for order picking.

- Press the two order picking switches at the same time for 1 sec to activate the coast control function.
- Select the Forward switch ON and press one of the order picking switches for 1 sec to deactivate the coast control function.



### CAUTION

Be sure the brake switch should be OFF position during activating the coast control function.

### Parking

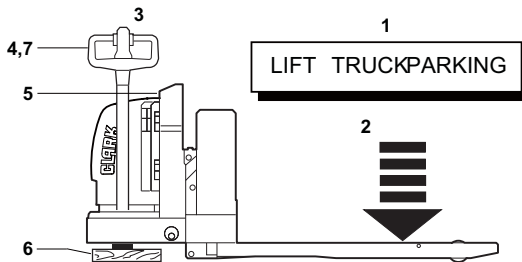

1. Park truck in designated parking area.
2. Lower forks to floor.
3. Place control handle in full turn and raise handle to "up" position to apply brake.
4. Turn key switch to "off" position and remove key.
5. Unplug battery connector.
6. Block drive wheel to prevent accidental roll.
7. Turn key in to proper authority.



# Daily Inspection

## Contents

Daily Inspection Sheet.....	5.2
Operator Repairs.....	5.2
Horn.....	5.3
Emergency Reversal Switch.....	5.3
Travel Control.....	5.4
Lift and Lower Controls.....	5.5
Brake .....	5.6
Coast Control (Option) .....	5.6
Wheels and Tires .....	5.7
Maintenance Problems.....	5.7

### NOTICE

OSHA requires inspection before starting each shift to keep lift trucks in safe operating condition. The following information points out important areas to check during these inspections.







## Horn • Emergency Reversal Switch

### Horn

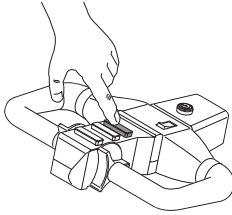

PWX Model

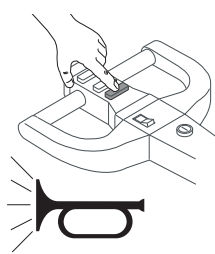

HWX Model

Check the horn. Make sure the horn works properly using both buttons.

### Emergency Reversal Switch

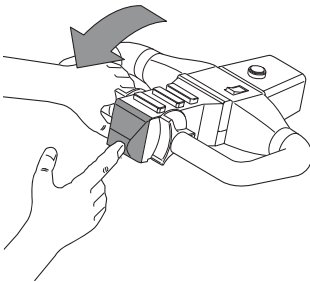

PWX Model

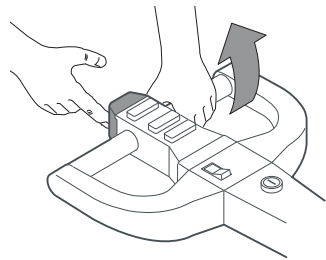

HWX Model

Check the emergency reversal switch. It should depress easily and pop back out on its own. Position the control handle to release the brake. Then, with the truck in "neutral" or "forward," depress the emergency reversal switch. The truck should move away from you until you take your hand off the switch or apply the brake.

# Travel Control

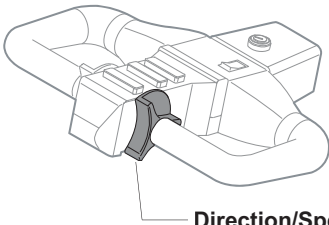

PWX Model

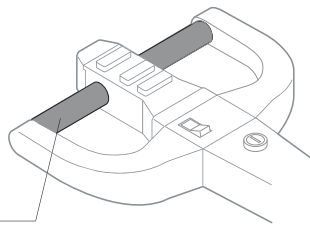

HWX Model

Direction/Speed Control

Check travel control. Operate truck in both forward and reverse directions. The direction/speed control must return to neutral position when released.

**Operator Hand Rail (HWX model only)** On the HWX, test the high-speed control: While riding the truck, rotate the direction/speed control to full forward speed. Depress the high-speed control button. The truck goes into higher speed and stays there until you return the throttle to neutral.

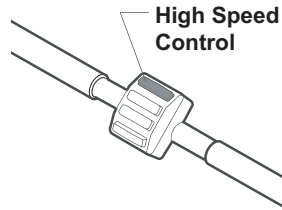

High Speed Control

## PWX Lift and Lower Controls

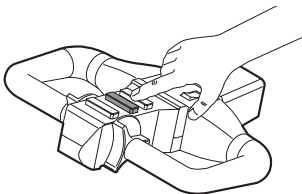
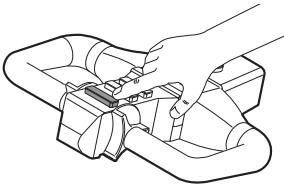

# Lift Controls

## HWX Lift and Lower Control

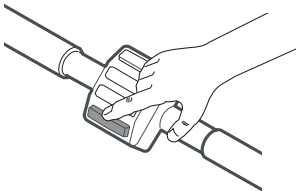
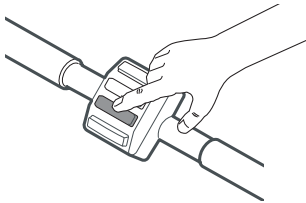
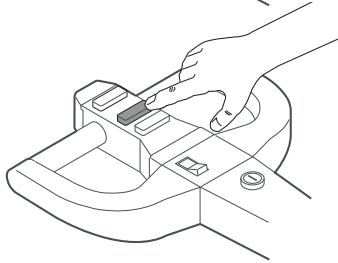
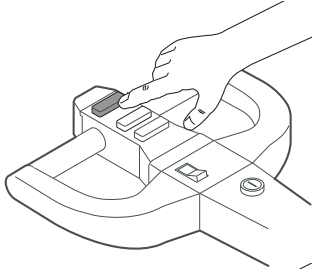

Check the lift/lower control buttons. The control buttons must return to the "off" position when released. The hydraulic lift pump motor should stop when maximum lift height is reached.

## Brake • Coast Control

### Brake

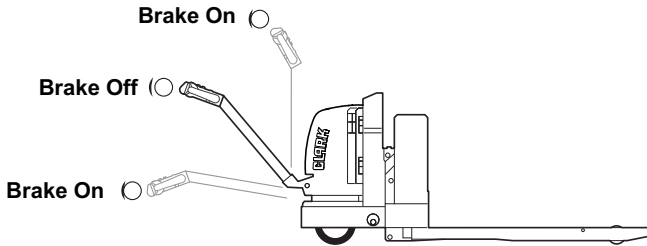

Check the brake. The brake should be applied with the control handle in the fully raised and fully lowered positions. The drive motor should stop when the brake is applied.

### Optional Coast Control (HWX Models)

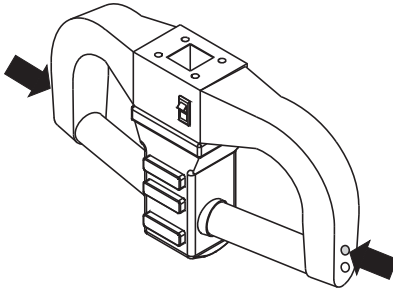

The coast control deactivates the brake and enables the truck to be "jogged" with the travel control and coasted for order picking.

- Press the two order picking switches at the same time for 1 sec to activate the coast control function.
- Select the Forward switch ON and press one of the order picking switches for 1 sec to deactivate the coast control function.



### CAUTION

Be sure the brake switch should be OFF position during activating the coast control function.

## Wheels and Tires • Maintenance Problems

### Wheels and Tires

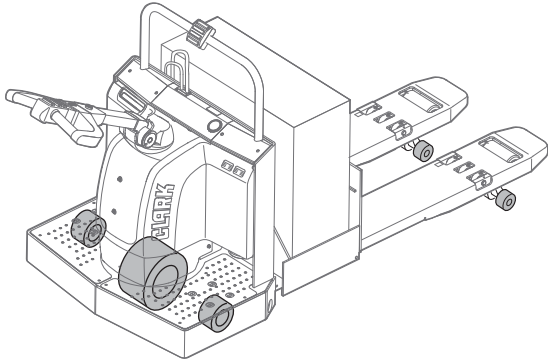

Check condition of wheels and tires. Remove any embedded objects. Report excessive wear, breaks, "chunking out", or bond failure. Check lug nuts for proper torque. Watch for loose wheel bearings.

### Maintenance Problems

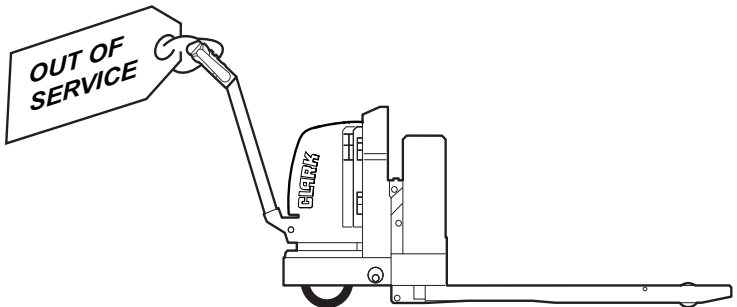

Do not operate a truck that has a maintenance problem. Park the truck properly and remove the key, if equipped. Put an "Out of Service" tag on the truck. Report the truck problem to the proper authority.



# Planned Maintenance and Lubrication

## Contents

Daily Inspection Points .....	6.2
Typical Operating Conditions.....	6.2
Maintenance and Lubrication Schedule .....	6.3
Safe Maintenance Practices.....	6.4
Safety Standards.....	6.7
Battery Maintenance.....	6.8
Battery Handling .....	6.9
Battery Charging.....	6.10
Battery Removal.....	6.11
Battery Cleaning and Care .....	6.12
Battery Service Records .....	6.12
Battery Life .....	6.13

### NOTICE

**THIS SECTION IS FOR TRAINED SERVICE PERSONNEL to use as a reference for Planned Maintenance procedures. Complete maintenance information is in the Service Manual.**



# Daily Inspection • Typical Operating Conditions

## Daily Inspection Points

The following should be done every 8-10 hours:

- Check truck for obvious damage and leaks.
- Check / clean battery terminals.
- Check battery electrolyte level and specific gravity.
- Check capacity plate, warning plates & decals.
- Check condition of tires and wheels and remove embedded objects.
- Check drive wheel lug nuts.
- Check hour meter and optional battery discharge indicator.
- Check brake operation.
- Check horn operation.
- Check emergency reversal switch operation.
- Check directional and speed control operation.
- Check lift and lower operation.

## Typical Operating Conditions

Time intervals between maintenance are largely determined by operating conditions. The intervals specified in the following table are for normal operation. For more severe operation, the maintenance intervals should be shortened accordingly. Contact your CLARK dealer for recommendations.

### Normal Operation:

Basically, eight hour material handling in clean buildings with smooth level floors and clean, open air.

### Severe Operation:

Prolonged operating hours or constant usage, with ramps and/or bumpy floors.

### Extreme Operation:

- Sandy or dusty locations.
- High temperature locations.
- Sudden temperature changes such as refrigeration facilities.





## Maintenance and Lubrication Schedule

### Recommended Planned Maintenance Intervals:

**A** = 8-10 hours daily

**B** = 50-250 hours or every month

**C** = 450 - 500 hours or every 3 months

**D** = 900 - 1000 hours or every 6 months

**E** = 2000 hours or every year

Planned Maintenance and Lubrication	A	B	C	D	E
Check truck for obvious damage and leaks		•			
Test drive truck-Check functional performance		•			
Air clean truck		•			
Check torque on critical fasteners		•			
Lubricate truck		•			
Clean/check battery terminals, electrolyte level		•			
Check battery cables & truck receptacle		•			
Perform battery load test		•			
Check motors		•			
Check lift pump motor brushes		•			
Test truck ground		•			
Clean drive motor air vents		•			
Check drive unit fluid level		•			
Drain and replace drive unit fluid					•
Check hydraulic fluid level		•			
Drain and replace hydraulic fluid					•
Check brake shoe lining		•			

# Safety Maintenance Practices

## SAFE MAINTENANCE PRACTICES

The following instructions have been prepared from current industry and government safety standards applicable to industrial truck operations and maintenance. They are listed here for the reference and safety of all workers during inspection / maintenance operations. When in doubt of any inspection / maintenance procedures, please contact your local CLARK dealer.

1. Powered industrial trucks can become hazardous if maintenance is neglected. Therefore, suitable maintenance facilities, trained personnel and procedures shall be provided.
2. Maintenance and inspection of all powered industrial trucks shall be done in conformance with the manufacturer's recommendations.
3. A scheduled planned maintenance, lubrication and inspection system shall be followed.
4. Only trained and authorized personnel shall be permitted to maintain, repair, adjust and inspect industrial trucks and in accordance with the manufacturer's specifications.
5. Properly ventilate work area, vent exhaust fumes, keep shop clean and floor dry.
6. Avoid fire hazards and have fire protection equipment present in the work area. Do not use an open flame to check electrolyte level. Do not use open pans of fuel or flammable cleaning fluids for cleaning parts.
7. Before Starting To Work On Truck:
  - a. Raise drive wheel free of floor or disconnect power source and use blocks or other positive truck positioning devices.
  - b. Put blocks under the load-engaging means, or chassis before working on them.
  - c. Disconnect battery before working on the electrical system.
  - d. When working on hydraulic system, be sure the battery is disconnected.
8. Operation of the truck to check performance must be conducted in an authorized, safe, clear area.

9. Before Starting to Drive the Truck:
  - a. Remove drive wheel chocks.
  - b. Plug-in battery connector.
  - c. Lower and turn control handle to operating position.
  - d. Insert key (if equipped) and turn to "on" position.
  - e. Make sure path of travel is clear.
  - f. Check function of controls and emergency reversal switch.
  - g. Check function of brakes.
10. Before Leaving the Truck:
  - a. Park truck in designated area.
  - b. Fully lower forks.
  - c. Raise and turn control handle.
  - d. Turn off key switch and remove key.
  - e. Unplug battery connector.
  - f. Block drive wheel.
11. Brakes, steering mechanisms, control mechanisms, warning devices, lights, lift overload devices, guards and safety devices, lift, reach and rotation mechanisms, and frame members must be carefully and regularly inspected and maintained in a safe operating condition.
12. Special trucks or devices designed and approved for hazardous area operation must receive special attention to ensure that maintenance preserves the original, approved safe operating features.
13. All hydraulic systems must be regularly inspected and maintained in conformance with good practices. Lift cylinders, valves and other similar parts must be checked to assure that "drift" or leakage has not developed to the extent that it would create a hazard.
14. When working on hydraulic system, be sure the battery is disconnected and forks are in the fully lowered position, and hydraulic pressure relieved in hoses and tubing.
15. The truck manufacturer's capacity, operation and maintenance instruction plates, tags or decals must be maintained in legible condition.

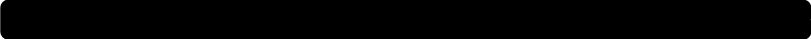
- 
16. Batteries, motors, controllers, limit switches, protective devices, electrical conductors and connections must be inspected and maintained in conformance with good practices. Special attention must be paid to the condition of electrical insulation.
  17. To avoid injury to personnel or damage to the equipment, consult the manufacturer's procedures in replacing contacts on any battery.
  18. Industrial trucks must be kept in a clean condition to minimize fire hazards and help in the detection of loose or defective parts.
  19. Modifications and additions that affect capacity and safe truck operation must not be done without the manufacturer's prior written approval. Capacity, operation and maintenance instruction plates, tags or decals must be changed accordingly.
  20. Care must be taken to assure that all replacement parts, including tires, are interchangeable with the original parts and of a quality at least equal to that provided in the original equipment. Parts, including tires, are to be installed per the manufacturer's procedures. Always use genuine CLARK or CLARK - approved parts.
  21. Use special care when removing heavy components from the truck, such as counterweight, upright, etc. The truck can become unstable and should be blocked. Be sure that lifting and handling equipment is of the correct capacity and in good condition.

### **IMPORTANT**

**Your new CLARK lift truck has been built to meet all applicable mandatory requirements of ANSI / ITSDF B56.1 Safety Standard for Powered Industrial Trucks. Each truck also includes certain safety devices-such as horn and overhead guard-as standard equipment. No additions, omissions, or modifications should be made that affect compliance to above requirements or in any way minimize the effectiveness of the safety devices.**

## Safety Standards

### NOTICE

**You should also be familiar with additional operating and maintenance safety instructions contained in the following publications:**

ANSI / ITSDF B56.1: Safety Standard for Low Lift and High Lift Trucks (Safety Code For Powered Industrial Trucks).

NFPA 505: Fire Safety Standard for Powered Industrial Trucks: *Type Designations, Areas of Use, Maintenance and Operation*. Available from: National Fire Protection Assoc., Inc., Batterymarch Park, Quincy, MA 02269.

General Industry Standards, OSHA 2206: OSHA Safety and Health Standards (29 CFR 1910), Subpart N - Materials Handling and Storage, *Section 1910.178 Powered Industrial Trucks*. For sale by: Superintendent of Documents, U.S. Government Printing Office, Washington, D.C. 20402 or contact your CLARK dealer.



## Battery Maintenance

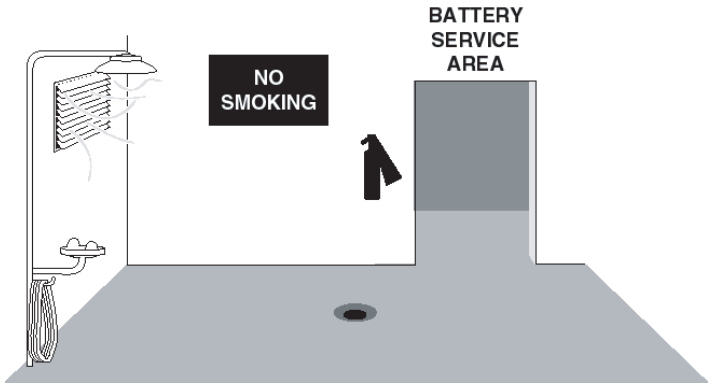

Battery charging installations must be located in areas designated for that purpose. These areas must be kept free of all nonessential combustible materials.

### Facilities must be provided for:

- Flushing spilled electrolyte.
- Fire protection.
- Protecting charging apparatus from damage by trucks.
- Adequate ventilation for dispersal of fumes from gassing batteries.

When handling acid concentrates greater than 50% acid (above 1.400 specific gravity), an eye wash fountain must be provided.

A conveyor, overhead hoist, or equivalent material handling equipment must be provided for handling batteries.

### IMPORTANT

**Electric truck batteries are heavy and awkward to handle. They are filled with a very hazardous chemical solution. On charge, they give off hydrogen which, in certain concentrations, is explosive. And, they are costly. Before you remove, service, or install a truck battery, carefully read the following recommendations and instructions.**

## Battery Handling

1. Change (remove) or service storage batteries only in an area designated for this purpose.
2. Be sure this area has provisions to flush and neutralize spillage, to ventilate fumes from gassing batteries, and for fire protection.
3. This area should be equipped with material handling tools designed for removing and replacing batteries, including a conveyor or overhead hoist. Use lift hooks that have safety latches.
4. Always use a special lifting device such as an insulated spreader bar to attach the hoist to the battery. The width of the spreader bar must be the same as the lifting eyes of the battery, to prevent damage to the battery. If the spreader bar hooks are movable, carefully adjust the position (width) of the hooks so that the pull is directly upward (vertical) and no side load or force (pressure) is exerted on the battery case. Be sure the lift hooks are the correct size to fit the lifting eyes of the battery.
5. If the battery does not have a cover of its own or has exposed terminals and connectors, cover the top with a non-conductive (insulating) material, such as a sheet of plywood or heavy cardboard, prior to attaching the lifting device.

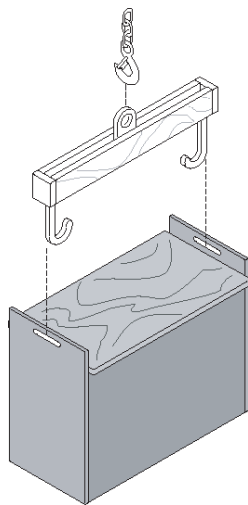

## Battery Charging

- Chain hoists or power battery hoists must be equipped with load chain containers to accumulate the excess lifting chain.
- Keep all tools and other metallic objects away from terminals.

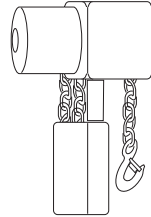

### WARNING

**BATTERY SERVICE must be done by trained and authorized personnel. Battery acid can cause severe burns and injury.**

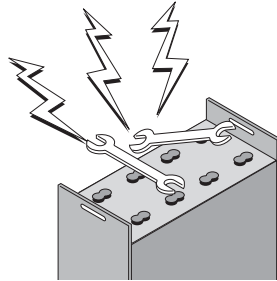

### Battery Charging

- Persons maintaining storage batteries must wear protective clothing such as face shield, long sleeves, and gloves.
- Hydrogen emissions from charging batteries are flammable. No smoking is allowed in the charging area. Do not check the electrolyte level with an open flame. Do not allow open flame, sparks, or electric arcs in battery charging area.



### WARNING

**SULFURIC ACID:** The battery contains corrosive acid that can cause injury. If acid contacts your eyes or skin, flush immediately with water and get medical assistance.



### WARNING

**EXPLOSIVE GASES:** Do not smoke or have open flames or sparks on battery charging areas or near batteries. An explosion can cause injury or death.



## Battery Removal from Truck

- When charging batteries, the vent caps must be kept in place to avoid electrolyte spray. Care must be taken to assure that vent caps are open (clean) and functioning. The battery (or compartment) cover(s) must be open to dissipate heat and gas.

### IMPORTANT

**If batteries discharge rapidly during normal operation or do not charge to the correct specifications, contact a qualified battery service technician to check the battery for you. Do not add electrolyte or attempt to service the battery.**

### Battery Removal from Truck

- Check the designated service and charging area for fire protection, and be sure all sources of ignition are cleared from the area. **Do not smoke.** Be sure all previous noted equipment is in the area, in good repair, and working properly. If the battery is to be serviced, be sure there are provisions to flush and neutralize spillage and to disperse (ventilate) fumes from gassing batteries on charge. And, be sure there are provisions for handling electrolyte.
- Before attempting to remove or charge a storage battery, the truck should be positioned in the designated battery service area and the parking brake applied so the truck cannot move.
- Disconnect the battery connector.
- If the battery to be handled is not equipped with its own cover, cover the battery when handling with a non-conductive (insulating) material, e.g., plywood or heavy cardboard, before attaching the lifting device.
- Use an approved lifting device with an insulated spreader bar, to remove and transport a truck battery. Be sure the hoist and lifting chains are equipped with safety hooks.
- Remove the battery and move it to a safe storage location. Store batteries either on an approved battery rack or on a wooden pallet.

### WARNING

Disconnect battery before handling electrical components. Polarity must be correct to prevent damage.

# Battery Cleaning • Service Record

## Battery Cleaning and Care

Never wash the battery when it is in the truck. The easiest and most satisfactory method of cleaning a battery is to wash it occasionally with a low-pressure cold-water spray. The top can also be washed off with a solution of baking soda and water (add a box of baking soda to a pail of water and stir until dissolved) and rinsed with clean water. It is good practice to have this solution in a battery room at all times.

### IMPORTANT

**During cleaning, the battery vent caps must be tightly in place.**

Refer to the battery manufacturer or supplier for their recommended battery maintenance and care procedures.

BATTERY SAVER and CLEANER, CLARK Part No. 886398, may be used to clean and protect the truck battery.

New Truck Batteries: Apply a light coat of BATTERY SAVER and CLEANER to entire surface of battery. Allow to set for approximately 30 seconds, then wipe thoroughly with a wiping cloth or rag. Chemical action will dissolve rust and corrosion. After cleaning, apply a second coating for protection. This will prevent the start and growth of corrosion on battery terminals and cable connections.

## Battery Service Records

Keep a record of battery service and maintenance to obtain the best service life from your battery and truck. Select a pilot cell, take readings of specific gravity and temperature before and after charging, and record the readings with the date. It is best to change the location of the pilot cell occasionally to distribute any electrolyte loss over the battery.

Every 2 or 3 months, take complete battery readings (specific gravity, temperature, and voltage) and make a record of them.

## Maximum Life • Battery Installation

### How to Get Maximum Battery Life

1. Follow normal battery maintenance procedures, re-charging before 80% discharged and with periodic equalizing charges.
2. Don't add acid to a battery. Only a person trained and qualified to do battery maintenance should determine if this is necessary.
3. Lift battery only with a correctly-constructed lifting device that will not put pressure on the battery case.
4. Keep open flames, tools, and metal objects away from the top of battery to prevent short circuits and explosions.
5. Do not overcharge.
6. Check the battery electrolyte level **after** each charging. Add water if the top of the separator or plates are visible. **Do not overfill!**
7. **Keep the battery clean and dry.** Wash down as needed.
8. Keep battery service records.

### Battery Installation

1. Use only a lead-acid battery with the voltage and ampere-hour rating specified for the truck.
2. When changing batteries on battery electric trucks, replacement batteries must be of the service weight that falls within the minimum/ maximum range specified on truck nameplate.
3. Handle battery only with approved lifting device.
4. Install the battery correctly in the truck and secure it in position.

#### NOTICE

**Some trucks are equipped with battery stops or blocks. Others do not require them. If the truck being serviced has battery stops or blocks, be sure none are missing or damaged. Replace them as necessary. If they are an adjustable type, be sure they are correctly adjusted and tightened.**



## Towing



**IMPORTANT**  
Pull a disabled truck by hand to a service area.



**CAUTION**  
Do not tow or push the truck with another vehicle.



# Specifications

## Model Designation — Rated Load Capacity

<b>PWX30</b> ; 6000 lbs [2721 kg]	<b>HWX30</b> ; 6000 lbs [2721 kg]
<b>PWX40</b> ; 8000 lbs [3628 kg]	<b>HWX40</b> ; 8000 lbs [3628 kg]

### Service Weight w/minimum battery

<u>Model</u>	<u>Battery Compartment</u>	<u>Service Wgt. w/min. battery</u>	
PWX 30	7"	1370 lbs	[620 kg]
PWX 30	13.6"	1780 lbs	[807 kg]
PWX 40	7"	1440 lbs	[653 kg]
PWX 40	13.6"	1850 lbs	[839 kg]
HWX 30	7"	1800 lbs	[816 kg]
HWX 30	13.6"	2030 lbs	[920 kg]
HWX 40	7"	1860 lbs	[843 kg]
HWX 40	13.6"	2280 lbs	[1034 kg]

### Battery

24 Volt Lead Acid, 12 cells

<u>Minimum Wgt.</u>	<u>Capacity (6 hr rate max)</u>	<u>Battery Compartment</u>
456 lbs	10.8 KW•h	7"
821 lbs	21.5 KW•h	13.6"

### Specific Gravity

<u>Minimum</u>	<u>Fully Charged</u>
1.160	1.315

### Fluid Recommendations

Hydraulic Unit	MS-68 Hydraulic fluid CLARK P/N 1800236
Drive Unit	MS-276A CLARK P/N 2776236

### Fluid Capacities

Hydraulic Unit	1.5 qts (nominal)
Drive Unit	2 -2.5 qts (nominal)

### General Purpose Grease

Clark Specification MS-107C, use grade NLGI #2 per MS-107C

# Index

- A**  
Application ..... viii
- B**  
Battery  
  Charging ..... 6.10  
  Cleaning and care ..... 6.12  
  Installation ..... 6.13  
  Maximum battery life ..... 6.13  
  Removal from truck ..... 6.11  
  Service records ..... 6.12  
Battery Handling ..... 6.9  
Battery Warning Decal ..... 3.12  
Brake ..... 3.8, 4.7, 5.6
- C**  
Coast Control Decal ..... 3.12  
Component Location  
  (*HWX Model*) ..... 3.3  
Component Location  
  (*PWX Model*) ..... 3.2  
Control Handle ..... 3.8
- D**  
Daily Inspection ..... 5.1  
Daily Inspection Points ..... 6.2  
Daily Inspection Sheet ..... 5.2  
Do's and Don'ts ..... 1.2  
Damaged Pallets and Skids ..... 2.6  
Debris on Floor ..... 2.5  
Dock or Trailer Drop-Offs .....  
Trailer Creep ..... 2.4  
Drive Unit ..... 3.8
- E**  
Electric Truck Battery  
  Maintenance ..... 6.8  
Electrical ..... 3.8  
Emergency Reversal Switch ..... 5.3  
Extreme Operation ..... 6.2
- F**  
Fast Turns ..... 2.2  
Fluid Capacities ..... 8.1  
Fluid Recommendations ..... 8.1
- Frame and Forks ..... 3.9
- G**  
General Purpose Grease ..... 8.1  
Grades ..... 1.5
- H**  
Horn ..... 5.3  
How to Get Maximum Battery  
  Life ..... 6.13  
HWX Lift and Lower Control ..... 5.5  
Hydraulic system ..... 3.9
- K**  
Know Your Truck ..... 3.1
- L**  
Long or Wide Loads ..... 2.3  
Loose Loads ..... 2.3
- M**  
Maintenance Component Location  
  (*HWX Model*) ..... 3.7  
Maintenance Component Location  
  (*PWX Models*) ..... 3.6  
Maintenance/Lubrication  
  Schedule ..... 6.3  
Maintenance Problems ..... 5.7  
Model Designation ..... 8.1
- N**  
Nameplate Description ..... 3.10  
No Passenger Decal ..... 3.12  
No Riders ..... 1.3  
Normal Operation ..... 6.2
- O**  
Operator's Controls  
  (*PWX Model*) ..... 3.4  
Operator's Controls  
  (*HWX Model*) ..... 3.5  
Operator Hand Rail  
  (*HWX model only*) ..... 5.4  
Operator's Manual ..... v  
Operator Repairs ..... 5.2  
Optional Coast Control  
  (*HWX Models*) ..... 5.6



**P**

Parking.....	1.8
Pedestrians.....	1.4
Pinch Points.....	1.7
Planned Maintenance and Lubrication .....	6.1
Publications, related Service .....	vi
PWX Lift and Lower Controls.....	5.4

**R**

Rated Load Capacity .....	8.1
---------------------------	-----

**S**

Safe Maintenance Practices .....	6.4
Safety.....	iii
Safety messages .....	vii
Safety signs .....	vii
Safety Standards .....	6.7
Severe Operation.....	6.2
Service Manual .....	vi
Service Weight.....	8.1
Specifications.....	8.1

**T**

Towing .....	7.1
Travel.....	1.6
Travel Control .....	5.4
Typical Operating Conditions.....	6.2

**W**

Wheels and Tires.....	5.7
-----------------------	-----

Serial Number:

Truck \_\_\_\_\_

Control Panel \_\_\_\_\_

Drive Motor \_\_\_\_\_

Hydraulic Unit \_\_\_\_\_



Additional copies of this manual may be purchased from  
YOUR AUTHORIZED CLARK DEALER



**CLARK**® Material Handling  
Company

700 Enterprise Drive  
Lexington, KY 40510  
Jun. 2012