

# Operator's Manual

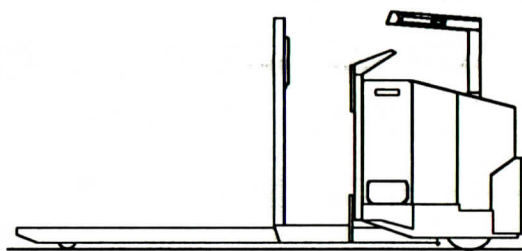

**PC & HPC 60**

---

**CLARK**

Book No. 2770273  
OM 546



## **WARNING**

**BREAKING THESE RULES WILL CAUSE SERIOUS OR FATAL INJURY TO YOURSELF AND OTHERS.**

- Do Not operate this vehicle unless you are trained and authorized. Read and understand the operator's manual before operating this vehicle. Clark dealers have replacement manuals.
- Turn off the master key switch when the vehicle is unattended. If this vehicle has no key switch, then disconnect the battery.
- Do not leave the "Coast Control Switch" in the coast position when the vehicle is unattended.
- Brakes do not automatically apply with "Coast Control Switch" in the coast position.
- Wear protective shoes and keep your feet clear of the vehicle when you are operating in coast position from the floor.
- Look where you drive. Watch out for people, obstructions and drop offs.
- Watch for obstacle interference with steer handle during sharp turns. Keep your hands on the designated grips and your feet away from the vehicle. Do not operate this vehicle with wet or greasy hands or shoes.
- Do not allow passengers to ride on this vehicle. This vehicle is not equipped for riders other than the operator.
- Do not operate damaged or faulty vehicle. Do not attempt repairs unless you are trained and authorized.
- This vehicle will tip over if it is not properly operated. Slow down before turning. Do not turn on slopes. Avoid uneven or slippery surfaces and loose materials.

## FOREWORD

Federal and state laws require that operators be carefully trained in the safe operation of industrial trucks.

Before you start operating this truck, make sure that you understand all driving procedures. It is important to operate your truck safely and efficiently.

This manual will help you learn how to operate your truck. It describes the controls, special features and their functions.

This manual is not a training manual. It is a guide to help authorized operators safely operate this truck. Instructions in this manual show the operator correct procedures for checking, starting, operating and stopping the truck. These instructions are not a substitute for proper training.

Clark industrial trucks are built to take hard work, but not abuse. They are built to be dependable, but as with any truck, they are only as efficient as the operator and the persons responsible for maintaining them.

Do not make any repairs to this truck unless you have been trained to make repairs and are authorized by your employer.

# TABLE OF CONTENTS

Foreword -----	Page 1
Table Of Contents -----	Page 2
General Safety Rules ----- Safety Alert Signal/Preliminary Service/Operator Training/ Level Floor/ ANSI B56.1-1983	Page 3
Summary Of Safe Operating Procedures ----- Trailer Loading/ Slow Turning/ Ramp Operation/Parking	Page 4
Know Your Truck ----- Controls/ Indicators/ Decal/ Name Plate Locations	Page 5 & 6
Controls And Indicators ----- Control/ Indicator Description	Page 7
Operating Hazards ----- Training/ Pedestrian/ Passenger/ Docks & Platforms/ Hazardous Locations/ Accident Reports/ Truck Modification/ Hand & Foot Protection/Trailers, Dock Boards & Elevators/ Floor Conditions	Page 8, 9 & 10
Before Operating Checks ----- Inspect Systems (Steering, Brakes, Controls, Retainers)/ Systems Operation (Horn, Direction Control, Brakes, Steering)/ Inspect (Tires, Indicators, Damage & Leakage)	Page 11 & 12
Operation ----- Traveling/ Parking	Page 13
Battery Retainment And Care ----- Retainers/ Spacing/ Voltage	Page 14
Maintenance ----- Daily-Annually/ Inspection/ Cleaning/ Greasing/ Fluids/ Brake/ Master Control Switch/ Drive Motor	Page 15
Lubrication ----- Chart/ Lube Points/ Fluids/ Greases/ Fitting	Page 16 & 17
Handy Reference -----	Page 18

# GENERAL SAFETY RULES

## IMPORTANT NOTICE



This is the industry's "Safety Alert Symbol". This symbol is used to call your attention to items or operations that could be dangerous to you or other persons using this equipment. It is essential that you read the instructions and safety regulations before you attempt to assemble or use this unit.

### PRELIMINARY SERVICE

Examine your Clark Electric Truck carefully to determine if it has been damaged in shipment. Any damage should be reported immediately to the transportation company.

### OPERATION

This truck has been designed for level floor operation and should be operated in accordance with instructions in ANSI B56.1-1983.

Do not operate the truck in hazardous areas.

### MESSAGE TO CLARK CUSTOMERS

Experience with lift truck accidents has shown that when accidents happen and people are killed or injured, the cause had its roots in three areas: the selection of operators, their training, and their supervision.

When lift truck operators are selected you must consider people who can become responsible professional operators. Lift trucks are not cars or ordinary trucks, they are specialized machines with specialized operating characteristics designed to perform specialized jobs. Under the Occupational Safety and Health Act you must train your lift truck operators, that is your responsibility. We are here to help, but only you know how a specific machine is used. Only you can properly train your operators for the jobs they must perform. Once they are trained and you are absolutely sure they know how to operate the equipment and follow basic safety rules, it's your responsibility to see these rules are followed. Failure to do so may result in accidents that end up in costly damage to your products, your facilities, your equipment, and worst of all, serious injury or death to the people who use these machines or work around them.

This book is designed to help your operators become professional lift truck operators. It cannot cover every possible situation which may result in an accident. We need your help; you must identify hazards in work areas and correct them. Your operators need your help. Make sure they learn the material in this book, the material in the operator's manual, and your company rules. Provide them with properly maintained equipment, give them time to practice under close supervision and repeat training often. Let's join together setting new standards in safety. If you need help with your training program, contact your local Clark dealer or Clark Equipment Company, Marketing Training & Communications, 525 N. 24th St., Battle Creek, MI. 49016.

# **SUMMARY OF SAFE OPERATING PROCEDURES**

## **PC 60**

Do not operate this truck unless you have been trained and authorized to do so. Read all warnings and instructions in the operator's manual and on this truck.

Do not operate this truck unless you have checked its condition. Give special attention to tires, horn, battery, controller, limit switches, brakes, and steering mechanism.

Operate only from designated operator's position for which instructions are given.

Do not carry unstable or loosely stacked loads. Use special care when handling long, high, or wide loads to avoid losing the load or striking bystanders.

Do not overload truck or pallets. Check capacity plate for load weight and size information.

Start, stop, travel, steer, and brake smoothly. Remember, loaded pallets will require a longer distance to stop the truck. Prepare for the extra distance, slow down for turns and on uneven or slippery surfaces that could cause the truck to skid or overturn.

Operate carefully on ramps; travel slowly and do not angle or turn.

Observe applicable traffic regulations. Yield right-of-way to pedestrians and emergency equipment. Slow down and sound horn at cross aisles or wherever vision is obstructed.

Do not travel with other personnel on the truck.

Before leaving the truck, make sure you have parked in an authorized area and are not blocking fire lanes, walkways, or stairways. Turn key switch (if so equipped) to the off position before leaving truck.



# KNOW YOUR TRUCK

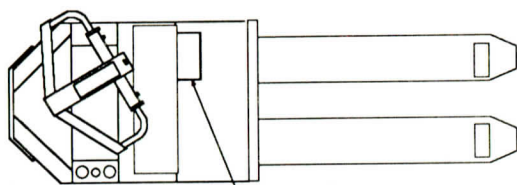

Brake Pedal

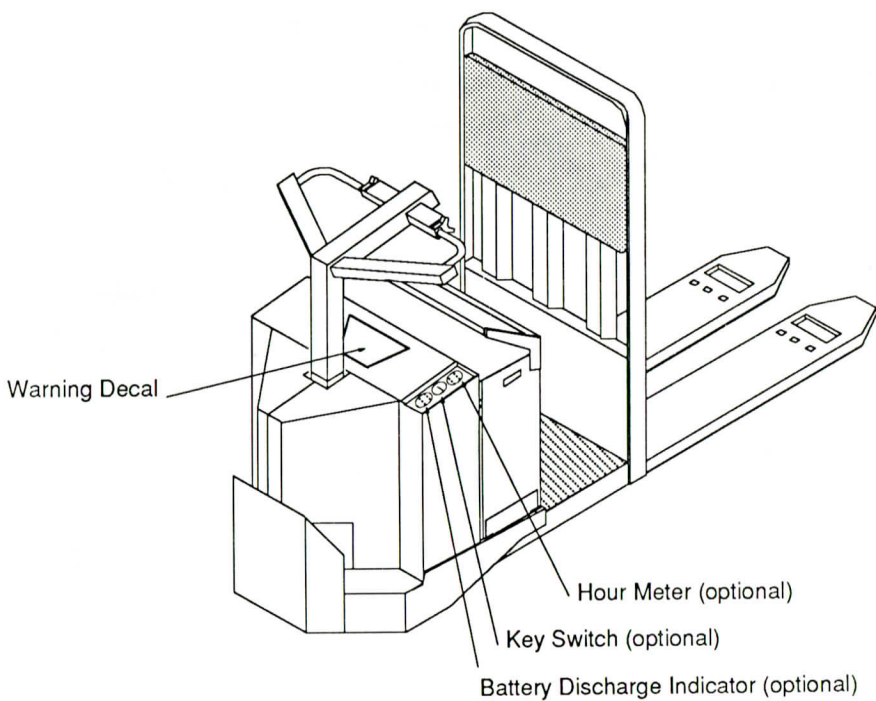

Warning Decal

Hour Meter (optional)

Key Switch (optional)

Battery Discharge Indicator (optional)

# KNOW YOUR TRUCK

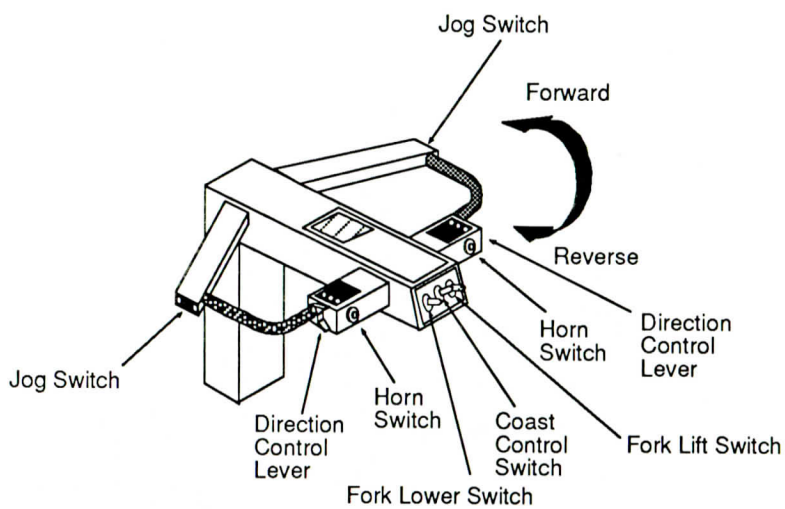



## CONTROLS AND INDICATORS

Key Switch (optional)	To prevent unauthorized use of truck -
Brake Pedal	This pedal is designed to apply the brake and stop the truck when in a raised position. Its operation should be checked before putting the truck into service. Its proper adjustment should be checked regularly and maintained.
Coast Control	The coast control switch has two (2) positions of use:  a. Coast position. This is used when the operator is walking along side the truck. The truck can only attain walking speed in this mode of operation and will coast to a stop. <b>THE TRUCK HAS NO BRAKE IN THIS POSITION.</b>  b. Brake, position. This is used when the operator is on the truck in the drivers compartment. The truck will attain maximum speed and is stopped by the brake pedal operation as described above.
Jog Switch	The Jog Switch is used in conjunction with the coast switch to give brief amounts of power to the drive unit of the truck. The direction of travel is chosen by pushing the switch in the desired direction. The truck will only attain walking speed.
Battery Discharge Indicator (optional)	Indicates battery charge condition: Red segment indicates discharged (dead) condition. Green segment indicates fully charged condition.
Hour Meter (optional)	Records the hours of truck operation.
Lift Switch	The forks will lift as long as the Lift Switch is depressed until they are fully raised.
Lower Switch	The forks will lower as long as the Lower Switch is depressed until they are fully down.

## OPERATING HAZARDS

Safeguard pedestrians at all times. Do not drive a truck up to anyone standing in front of a bench or other fixed object.

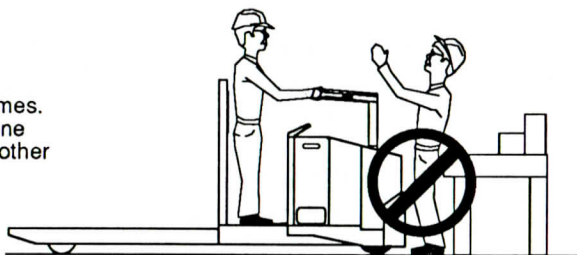

Maintain a safe distance from the edge of docks and platforms when operating powered industrial trucks. Use caution when the floor is slippery from ice, water, grease, or loose material.



Do not use this truck in explosion and fire hazard locations.



## OPERATING HAZARDS

Report all accidents involving personnel, building structures, and equipment.



Do not block access to stairways and/or fire equipment.

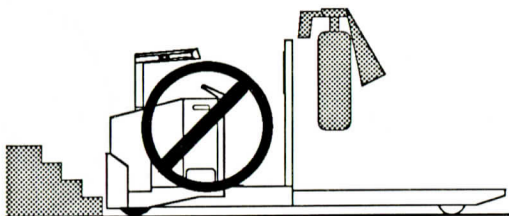

Keep hands and fingers inside the protected area of the control handle when traveling or turning while in the riding position.

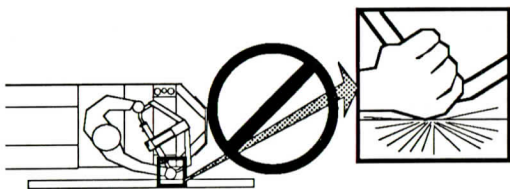

Before entering trailers be certain that dock boards are secure and trailer wheels are blocked to prevent rolling.

Do not enter trailers or elevators unless you know the allowable floor load limits.

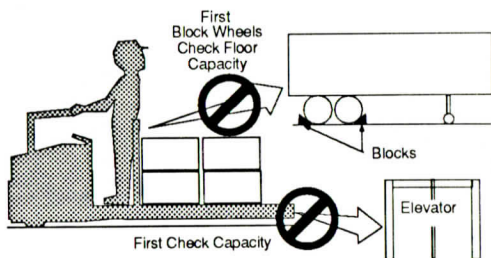

## OPERATING HAZARDS

Always climb or descend grades with the load on the lower end of the truck

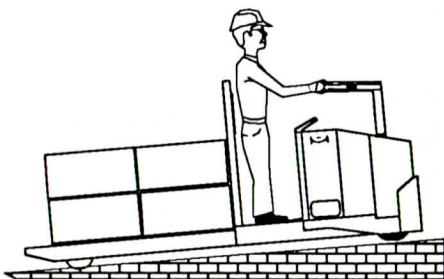

Do not travel with loose or unstable loads.



This truck is intended for use only on smooth level floors.



When walking beside this truck, be careful to keep your feet from under the truck or the wheel may run over them.

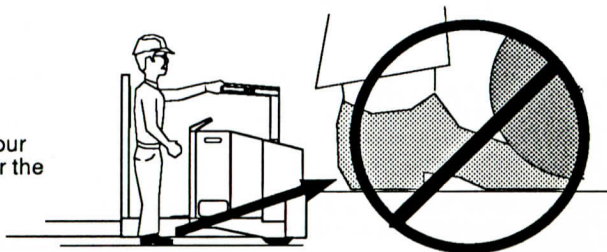

## BEFORE OPERATION CHECKS

Inspect truck, looking for damage and leakage. DO NOT operate the truck until it is repaired.

Inspect steering for looseness or lack of lubrication. Turn the steering handle fully left, then right. Steering should turn smoothly without binding or any loss of control.

Inspect drive unit. Look for leakage.

Check all wheels for flat spots or missing pieces.

Make sure the operator's manual is kept with the truck.

Check the condition of electrical cables and wiring and make a report of all worn or cracked cables.

Connect the battery to truck (if disconnected), and turn the key switch (if so equipped) to the "ON" position.

Check the charge condition of the battery. If gauge reads in red area, have battery charged before operating truck.

Press horn button to check horn function. If horn does not function, report the failure and have it repaired before the truck is put into operation.

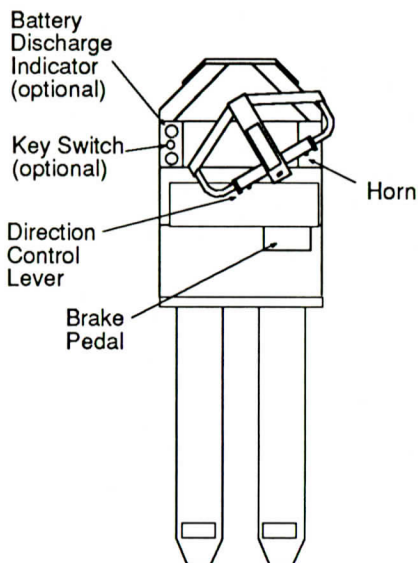

## BEFORE OPERATION CHECKS

Before operating the truck look in all directions to make sure your path is clear.

Put your foot on the brake pedal and press down. This will release the brake and energize the drive motor.

Turn handle until steering is in the desired direction of travel.

Turn directional control lever forward (away from you) slowly. The truck must move slowly in a forward direction. Push lever more to increase speed. Truck should accelerate smoothly to maximum speed. Return lever to "Neutral" position and remove your foot from brake pedal to stop truck.

Turn directional control lever backwards (towards you) slowly to move truck in reverse direction. The truck must move slowly in reverse. Pull lever more to increase speed. Truck should accelerate smoothly to maximum speed. Return lever to "Neutral" position and remove your foot from brake pedal to stop truck.

Lift foot from brake pedal to apply brake and stop truck travel.

Brake action should be smooth. The truck should stop in a normal distance. Note any unusual brake operations.

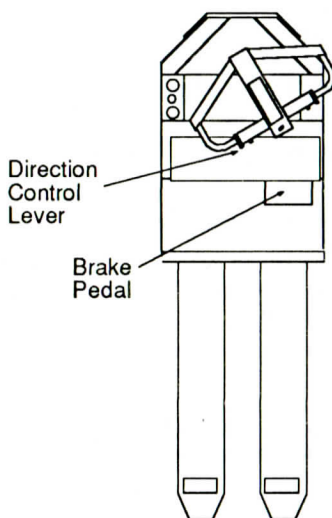



# OPERATION OF THE PC 60

## Traveling

Connect the battery , if not connected.

Enter the operator's compartment.

Turn the key switch (if so equipped) to the "ON" position.

Put your foot on the brake pedal and press down. This will release the brake and make power available to the drive motor.

Turn steering handle until steering is in the desired direction of travel.

Look in all directions to make sure that your path of travel is clear.

Turn directional control lever slowly in the direction you want to travel.

Lift your foot from the brake pedal to activate the truck brake and stop truck travel.

Your truck can be operated while standing in the forward or reverse direction of travel.

Your truck can be operated while walking along side by turning the coast control switch to coast position and pushing jog control switches in the direction that you want to travel.

The jog control switches are located on either end of the control handle.

The rate of travel when using the jog control switch is about walking speed.

## Parking

Park trucks in authorized areas only.

Make sure truck does not block fire aisles, fire equipment, stairways, or walkways.

When leaving truck, make sure that the circuit switch (if so equipped) has been turned to "OFF" position and key had been removed. Remember to put chocks against the wheels if truck is left on an incline.



## BATTERY RETAINMENT AND CARE



### WARNING BATTERY SERVICE

BATTERY ACID IS VERY CAUSTIC.  
BATTERY SERVICE MUST BE DONE BY TRAINED  
PERSONNEL.  
BATTERY ACID CAN CAUSE SEVERE BURNS AND  
INJURY.

Make sure that the battery retainers are in proper position and secure.

Do not drive truck if the battery can move horizontally more than .50 inches.  
Provide solid blocking to limit battery movement to .50 inches.

Use battery of proper voltage.

PC-60 12 or 24 volt battery  
HPC-60

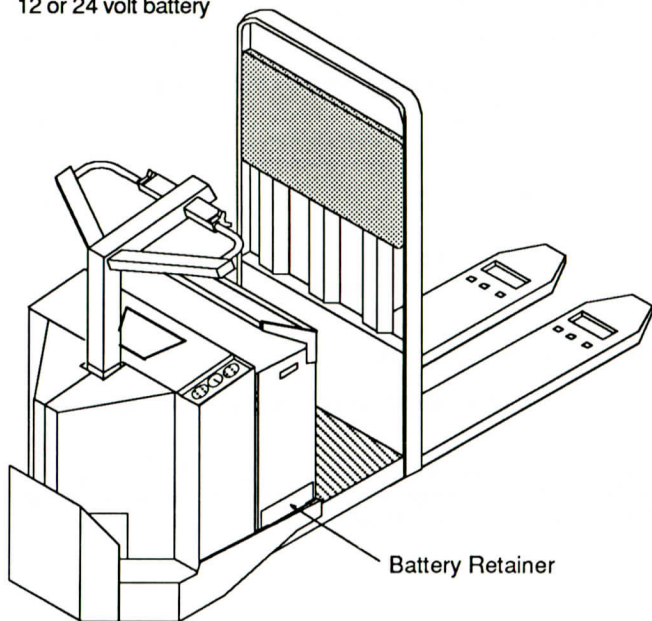

# MAINTENANCE

## DAILY

Charge, service, and clean battery. Inspect visually for damage or leakage.

Inspect visually for loose or missing parts.

Inspect visually for foreign material in the fork mechanism.

Check electrical interlock (brake switch) operation.

Check for smooth and proper functioning of all controls.

Tighten any loose bolts, nuts.

## WEEKLY

Check level of hydraulic fluid, (SAE 10-40 oil should be within 1 inch of fill opening with fork lowered - see lubrication chart.)

Check transmission lubricant level by removing the pipe plug below intermediate gear bearing cover. Use 80W90 APIGL-5 transmission grease.

Check battery water level.

Equalize battery charge (see manufacturer's instructions).

## MONTHLY

Service all grease fittings (see lubrication chart).

## SEMI-ANNUALLY

Thoroughly scrub battery.

Thoroughly clean machine.

Carefully inspect for loose or missing parts. Tighten or replace as required.

## SEMI - ANNUALLY (CON'T)

Inspect for wiring damage.

Check contactors.

Check brake adjustment.

Service drive and pump motors (see manufacturer's instructions)

Lubricate steer handle bearings (see lubrication chart).

## ANNUALLY

Drain, flush and refill gear case (see lubrication chart).

Check all adjustments.

## BRAKE

This brake is electrically released and (spring)mechanically applied. It is to be repaired and adjusted only by a mechanic trained in its maintenance.

## MASTER CONTROL SWITCH

This switch is located in the side of the handle. It controls the travel direction of the truck. This switch is not adjustable and if defective must be repaired or replaced.

## DRIVE MOTOR

The commutator should be checked for dirt, wear, or damage. Clean, repair, or replace as required.

# LUBRICATION

## LUBRICATION

To obtain maximum life of any industrial equipment, a well planned maintenance program should be followed. The following is intended to provide guidelines for proper lubrication intervals as called out in the lubrication chart. Some operating conditions will require more frequent checks and lubrication than listed. For example, applications with much dust or moisture will require modification of the schedule to fit that particular application.

High grade lubricants and fluids should be used. Those listed on page 17 are typical and any lubricant with equal specifications may be used.

## FLUSH GREASE FITTING

Flush grease fittings are used throughout this electric truck. The adapter for greasing the fittings is available at your dealer under the part number 861632.

# LUBRICATION

LUBRICATION				
1	Gear Case Transmission	Drain Flush and Refill	80 W 90/ API GL-5	500 HRS
2	Load Wheel Axle	Use Lube Gun & Adapter for Flush Type Fittings	Tex. Ref. C&C #880	150 HRS
3	Wheel Fork Pin Bearings	Remove, Clean, & Oil	SAE- 40W Motor Oil	150 HRS
4	Pull Rod Pin Bearings	Remove, Clean, & Oil	SAE- 40 W Motor Oil	150 HRS
5	Cylinder Rod Pin Bearings	Remove, Clean, & Oil	SAE- 40 W Motor Oil	150 HRS
6	Hydraulic Reservoir Inlet Screen Inside of Reservoir	Clean In Solvent	Solvent	2000 HRS
7	Hydraulic Reservoir	Drain, Flush, & Refill. Fill to 1" below the opening with forks fully lowered.	SAE- 40 W Motor Oil	2000 HRS
8	Hydraulic Oil Filter	Change Filter	Filter	250 HRS
9	Steer Handle Bearings	Remove, Clean, & Oil	SAE - 40 W Motor Oil	150 HRS
10	Frame Casters	Use Std Lube Gun	Tex. Ref C&C #880	150 HRS

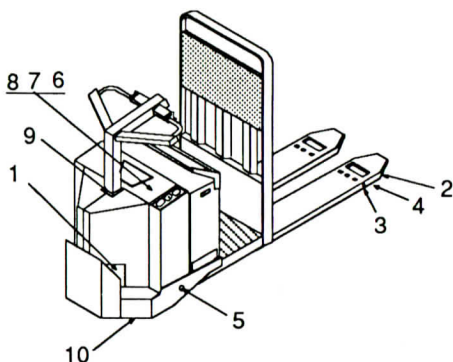

## HANDY REFERENCE

Model Number ----- \_\_\_\_\_  
Serial Number ----- \_\_\_\_\_  
Battery  
Number ----- \_\_\_\_\_  
Weight ----- \_\_\_\_\_  
Voltage ----- \_\_\_\_\_  
Truck Capacity ----- \_\_\_\_\_  
Customer Truck Number ----- \_\_\_\_\_





Additional copies of this manual may be purchased from  
YOUR AUTHORIZED CLARK DEALER

---

---

**CLARK**

Asheville, NC 28776  
Battle Creek, MI 49016  
Georgetown, KY 40324  
St. Thomas, Ontario, Canada N5P 1H2