

Operator's Instruction Manual

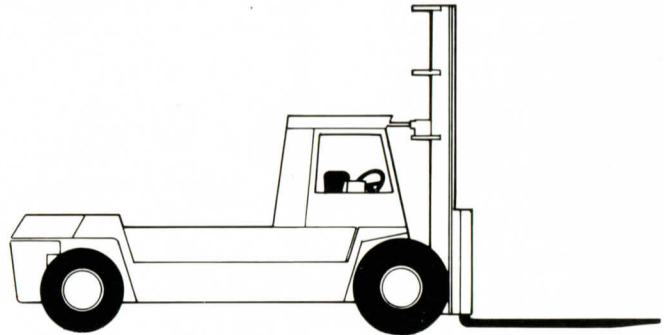

C500(Y) 800

CLARK

Book No. 2385968
OI-416 2nd Rev

TABLE OF CONTENTS

Foreword	Page 1
Know Your Truck	Page 2
Safety (Safe Operating Rules and Practices)	Pages 3-14
Operator's Compartment and Controls (C500 Y800 Model)	Page 15
Operator's Compartment and Controls (C500 Y800 Model)	Page 16
Before Operation Checks	Page 17
On the Ground Checks	Pages 17-18
Maintenance Checks	Pages 19-21
Starting the Engine	Pages 22-23
Instruments Check	Pages 24-25
Hydraulic Controls Check	Pages 26-27
Horn and Steering Check	Page 28
Transmission Controls Check	Page 29
Completion of Checklist	Page 30
Operating Hints	Pages 31-32
Parking	Page 33
Helpful Hints	Pages 34-36
Tire Pressure, Fork Adjustment & Cold Start	Page 34
Engine Oil Recommendations (Diesel)	Page 35
Fuel Recommendations (Diesel)	Page 36
Handy Reference Chart	Page 37

FOREWORD

A large share of the total cost of most every product can be traced to handling. This includes in-plant transport, storage, freight, warehousing and final delivery. In many cases, the fork lift truck plays a key roll in each of these operations.

You and your lift truck can significantly reduce these costs . . . or increase them. A lift truck costs thousands of dollars. Add to this the cost of operation (operator's pay, fuel, maintenance, fringe benefits, etc.) and it can easily be seen that this is an important investment for any company. The investment has now been made and it is up to you to ensure that maximum return is realized.

This manual will help the "Qualified Operator" become familiar with the lift truck's major components, its operating controls, special features and the function(s) of each.

This publication is not a training manual but rather, a guide to help the "Qualified Operator" to more safe and efficient operation of your Clark lift truck.

Operator training manuals are available through your Clark Dealer.

Clark trucks are built to take hard work not abuse. They are built to be dependable, but — as with any other truck — they are only as good as the person behind the wheel and the people responsible for maintaining them.

Illustrations in this manual guide the operator through correct procedures for checking, starting, operating, stopping and parking the lift truck.

Read it — Study it — Keep it Handy.

Know Your Truck

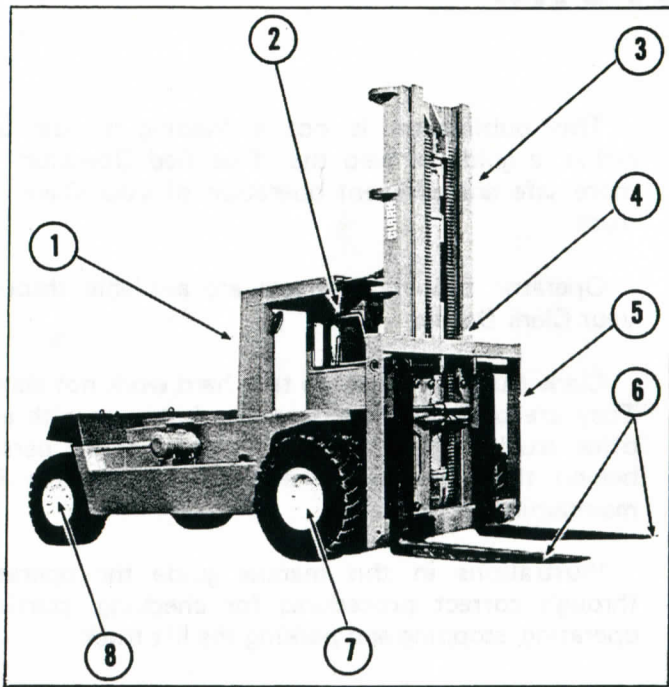

1. Overhead Guard
2. Operator's Compartment and Controls (see pages 15 and 16.)
3. Upright Assembly
4. Upright Deck Number
5. Fork Carriage
6. Load Forks
7. Drive Axle and Wheels
8. Steer Axle and Wheels

A1409

CLARK C500 Y800

Rated capacity of 80,000 lbs. with a 48 inch load center. Pneumatic tires with 4 speed powershift transmission and a Cummins diesel engine.

Safety

1. Only physically qualified and thoroughly trained personnel shall be authorized to operate the Clarklift C500 Y800.
2. Prominently placed on every Clark truck is a list of basic rules for operation. These rules are for the protection of you and others in your operating area. Be familiar with them.

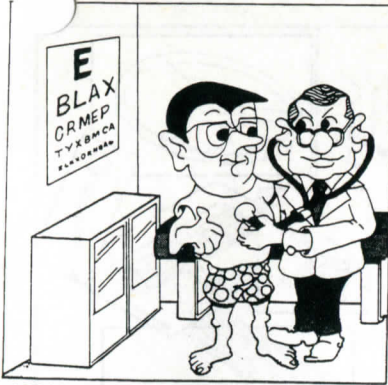

13696

A1395

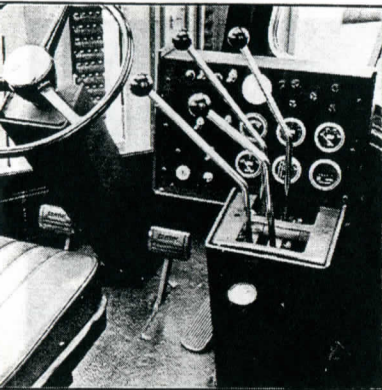

Code: OI-416 October 78

3. Learn how your truck is operated. Know its safety devices, how they function and how the special attachments, if any, work. Refer to pages 15 and 16 for specific control identification.

4. The wearing of safety glasses, safety shoes and hard hat is recommended. Dress suitably and avoid loose fitting clothing.



13110

19320

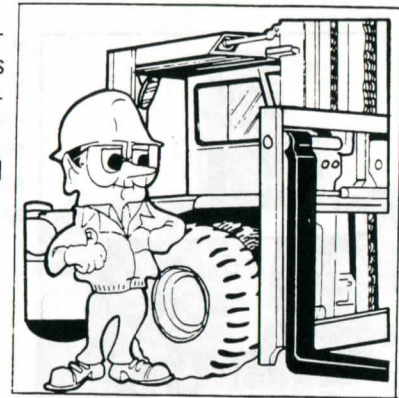

Page 3

Safety



A1410

5. Never operate a lift truck with wet or greasy hands or shoes.

6. Before operating any lift truck test the horn, brakes, parking brake, steering, lift-tilt controls, directional controls, range controls and special devices for proper operation. Report any improper operation to the proper authority.

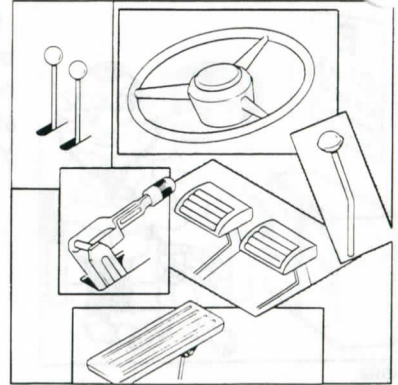

13318

A1390



7. Always look all around the truck before moving it in any direction. Then remember to start and stop slowly and smoothly.

8. Operate the truck only in designated truck routes and keep operating aisles clear. One-way traffic is recommended. If this is not practical in your operation heed highway regulations and drive to right of aisle centerline.



19321

Safety

9. Be alert for pedestrians, other trucks or obstacles in your path of travel.

10. Sound horn at all corners, exits, entrances and when approaching pedestrians or bystanders.

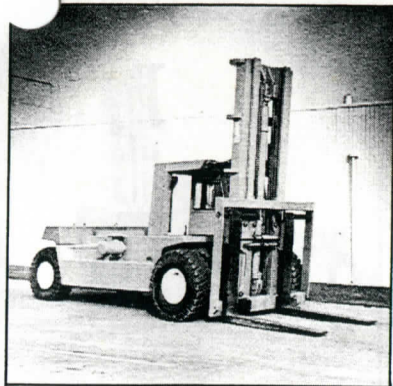

A1398

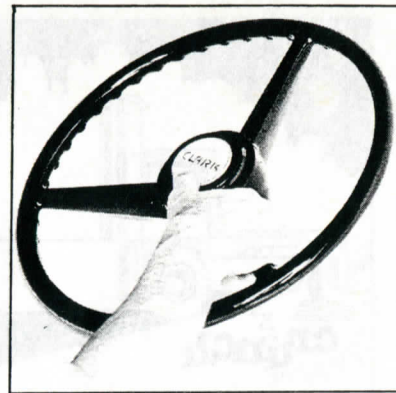

13141

19324

13087



11. Obey all posted traffic rules and warning signs.

12. Maintain a safe distance from the truck ahead of you at all times.

Assure ample distance to stop smoothly and safely should the need arise.

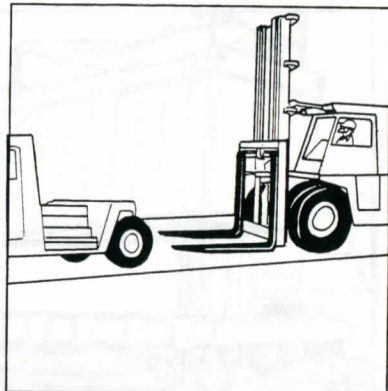

Safety

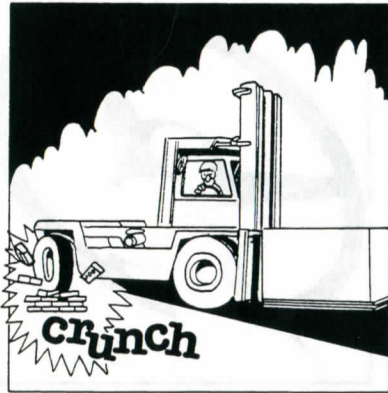

19323

19322

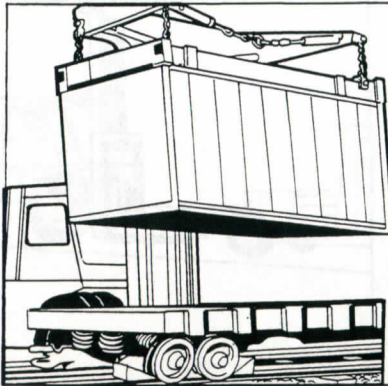

Page 6

13. Be aware of rear end swing and be alert to prevent rear end swing damage to material in your operating area.

14. Be aware of the position of your fork tips when the truck is in motion. Be alert to prevent striking anything with fork tips.

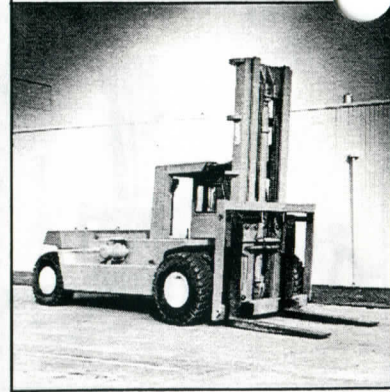

A1398

19325

15. Make certain that vehicle being loaded or unloaded has been securely "chocked" to prevent accidental roll.

Fixed jacks will be necessary to support the front end of semi-trailers when not attached to the tractor.

16. Never allow stunt riding or indulge in horseplay while operating a fork lift truck.

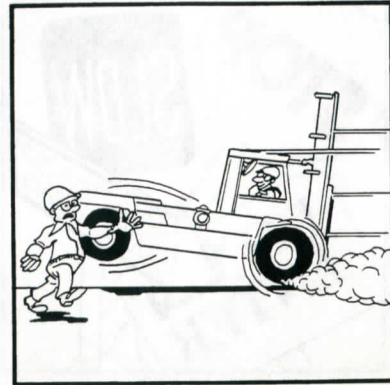

Code: OI-416 October 78

Safety

17. Never use your truck to push or tow another. Never allow your truck to be pushed or towed by another.

Should a truck become disabled and require moving, notify the proper authority immediately.

18. Never carry unauthorized passengers. The quick response of a lift truck may cause riders to fall off. Besides, they distract you and this could be dangerous.

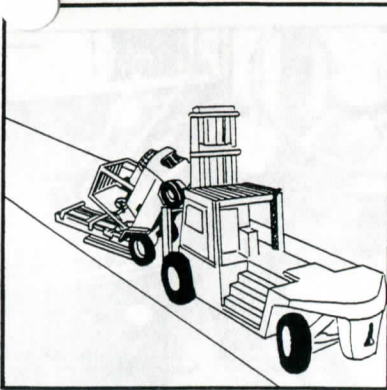
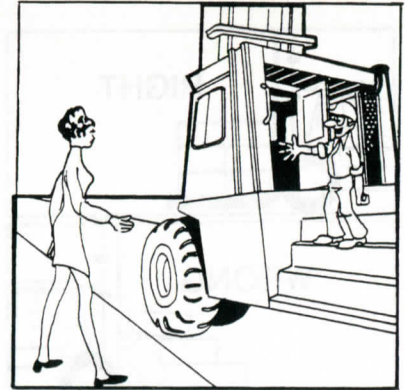

19326

19329

13095

19328

CLARK EQUIPMENT		1	
INDUSTRIAL TRUCK DIVISION BATTLE CREEK MICH		TYPE 3	
MODEL NO.	2	3	
SERIAL NO.	4		
ATTACHMENTS			
LOAD C.G.	5		
FLOOR	6		
APPROX. WT. ALL TRUCKS	7		
APPROX. WT. ELECTRICS ONLY	8		
BATTERY WT.	9		
BATTERY CAPACITY	10		
FOR OTHER CAPACITIES CONSULT MANUFACTURER AS RELEASED FROM FACTORY THIS TRUCK MEETS THE DESIGN SPECIFICATIONS ESTABLISHED IN AMERICAN NATIONAL STANDARD FOR POWERED INDUSTRIAL TRUCKS PART II, ANSI B 56.1-1969 PT NO 2315709			

19. Know the rated capacity of your truck and its attachment (if any) and never exceed it. Study your truck data capacity plate and learn the facts stamped in areas 1 through 8. Note "type" stamped in area 3 and refer to item 42 on page 13.

20. Thoroughly inspect all loads to be moved for overload and/or poor balance. If the stability of a load is questionable, don't move it.

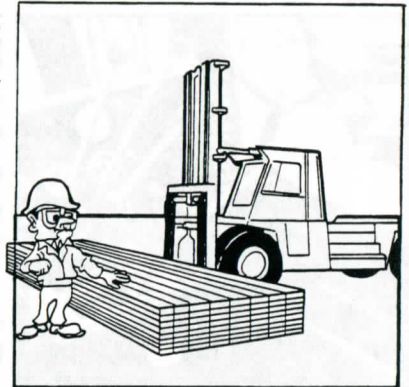

Safety

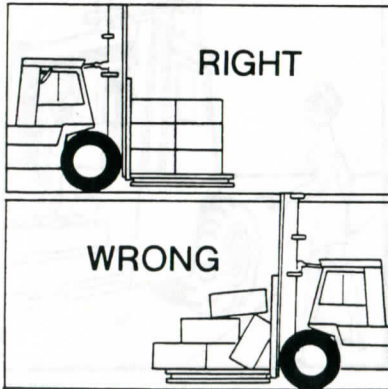

19327

A1382

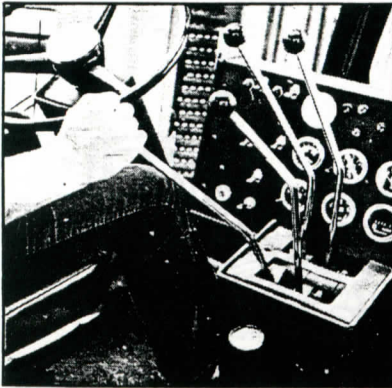

Page 8

21. Unstable loads are a hazard to you and to your fellow workers. Always make certain that your load is well stacked and evenly positioned across both forks. Never attempt to lift a load with only one fork.

23. Before lifting check to insure adequate unobstructed overhead clearance.

Gradually and smoothly pull back on lift control lever.

Return control lever to neutral position to stop lift at desired level.

22. Check hydraulic control levers to make sure linkage is in good condition.

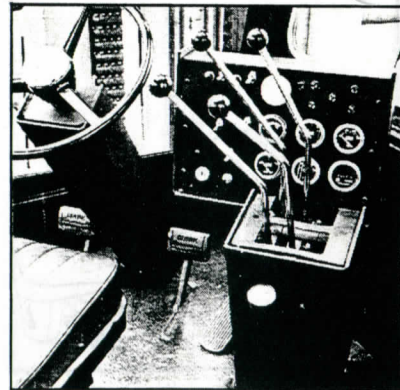

A1395

A1383

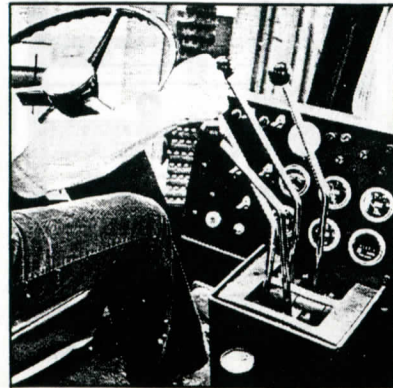

24. Push control lever forward to lower load. Descent of load may be stopped at desired level by returning control lever to neutral position.

Safety

25. Travel with load near operating surface and with upright tilted back to cradle load whenever possible.

Never lift or lower load when truck is in motion.

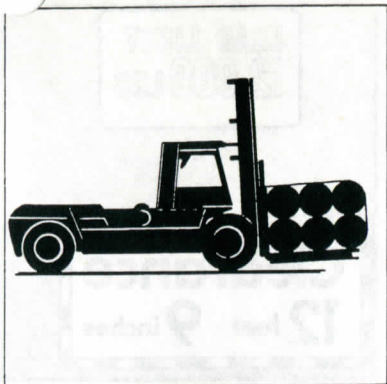

19330

26. When extra length of material being handled makes it necessary to travel with load elevated, do so with extreme care and be alert to load end swing when turning.

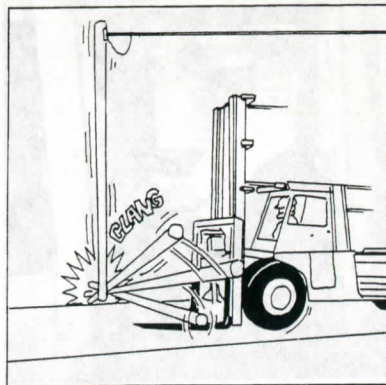

19331

13103

27. Never permit anyone to stand or walk under elevated forks or other load engaging attachments if machine is so equipped.



14631

28. Slow down for turns, ramps, bumps, intersections, wet or slippery operating surfaces and at all times when your visibility is restricted.

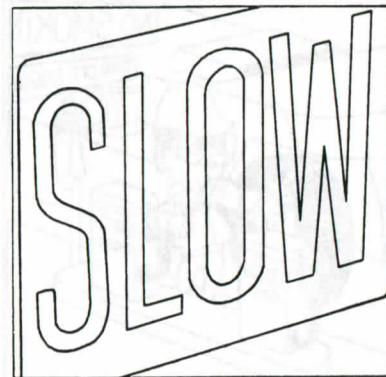

Safety



A1389

29. Remain seated at all times and keep head, hands, arms, feet and legs within the confines of the operator's compartment.

Never reach into the upright for any reason.

30. Know and observe overhead clearances and bridge or floor load limits in your operating area.



13102

19332

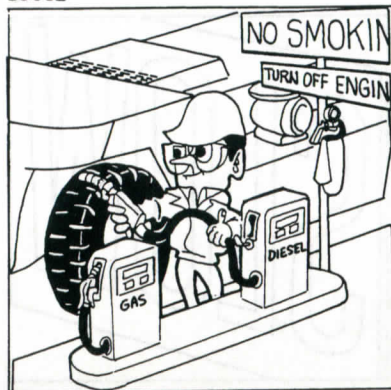

31. Lift trucks must be refueled in designated areas only. Engines must be stopped and no smoking regulations strictly enforced.

Spilled fuel must be washed away or completely evaporated and the fuel tank cap replaced before restarting the engine.

32. Never smoke or allow anyone to smoke in areas where batteries are being charged or in areas where fuels or other flammable fluids or materials are used or stored.

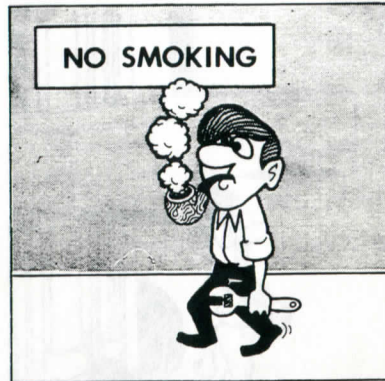

13107

Safety

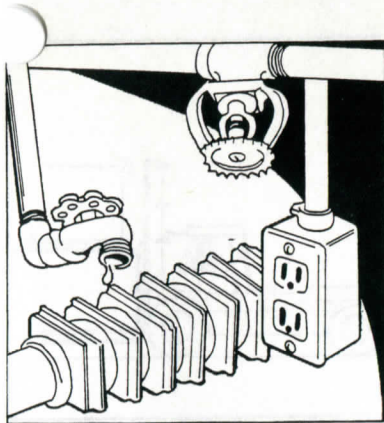

13104

A1386

33. Use caution when placing loads or traveling near water pipes, overhead sprinklers, electrical wiring, steam pipes, heaters or other fragile or dangerous equipment or material.

34. Park lift trucks in designated areas only. Lower forks to floor, tilt upright forward, apply parking brake, place all controls in neutral. Remove switch key and securely block the drive wheels.



19333

19336

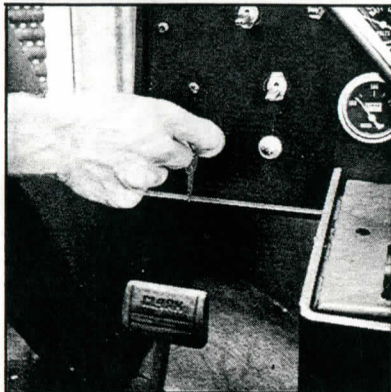

35. If truck is to be left unattended make certain that operating aisles are unobstructed and leave truck as described in item 34.

36. When handling bulky loads which, because of their size and shape, restrict your vision — operate your truck in reverse to improve visibility.

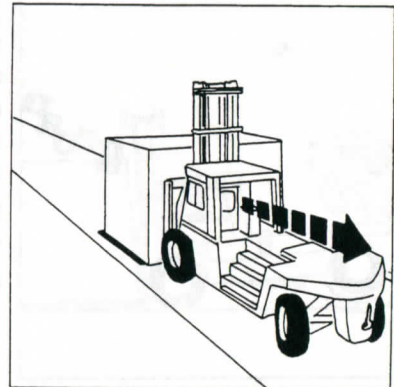

Safety

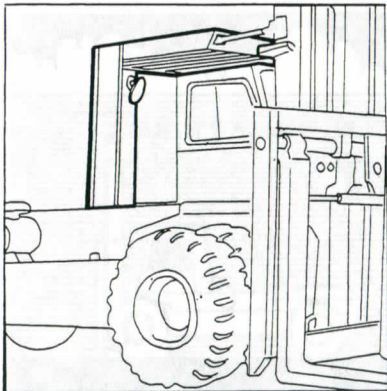

19335

19337

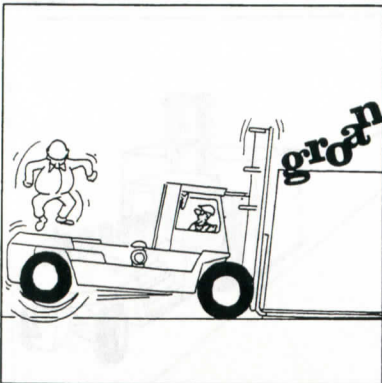

37. Overhead guards are for your protection. Make certain that they are secure and undamaged before operating your truck.

38. Don't handle double tiered loads. They're unstable and difficult to control. Even an overhead guard can't fully protect you from heavy objects dropped from these heights.

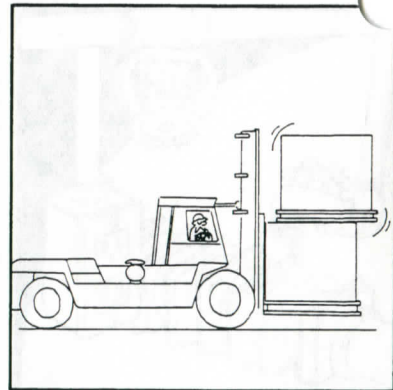

19334

19338

39. Overloading is extremely dangerous. You don't have complete control of your truck and you are causing unnecessary wear.

Never add to your counterweight, always break down the load.

40. Don't pass other trucks traveling in the same direction at intersections, blind spots or other dangerous locations.

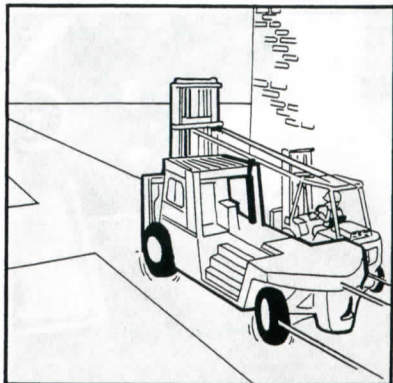

Safety

41. Do not use your lift truck to raise personnel.



17631

A1399

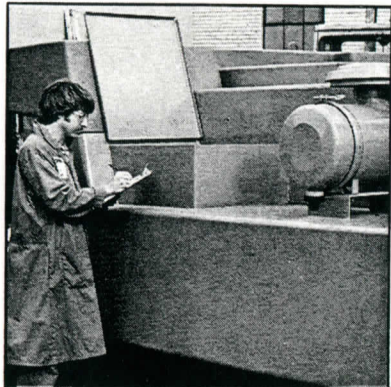

43. Follow a scheduled planned maintenance and lubrication program.

All adjustments and repairs must be performed by thoroughly trained and authorized personnel only.

42. Know the construction type of your truck and make certain that trucks of this type may be operated in restricted areas before entering. Never take an unauthorized truck into restricted or hazardous areas.

AU 1516
CLASSIFIED BY UNDERWRITERS
LABORATORIES, INC. AS TO FIRE
AND ELECTRICAL SHOCK HAZARDS
ONLY. TYPE EE INDUSTRIAL
TRUCK. SEE UL INDEX OF
CLASSIFIED PRODUCTS.

148800

AU 1674

CLASSIFIED BY UNDERWRITERS
LABORATORIES, INC. AS TO FIRE
HAZARD ONLY. TYPE LPS
INDUSTRIAL TRUCK. SEE UL
INDEX OF CLASSIFIED PRODUCTS.

149639

13178

A1398

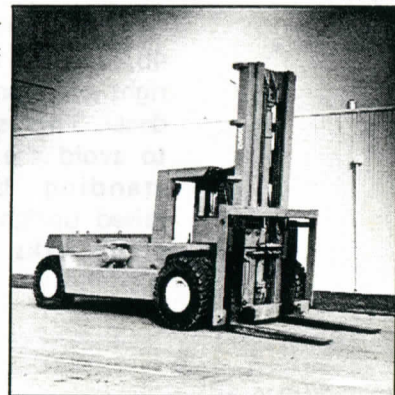

44. Remember — your safety and the safety of others depends on you. Keep your mind on operating your lift truck.

Safety

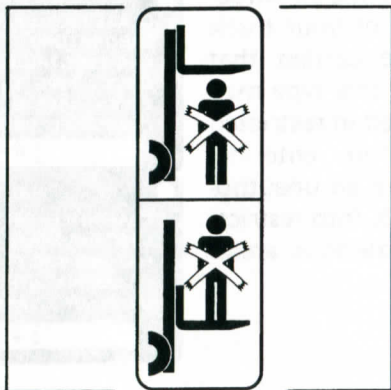

19340

45. Located on the upright cylinder is a safety decal. This is a warning to avoid the danger of standing beneath a raised upright or riding on the forks.

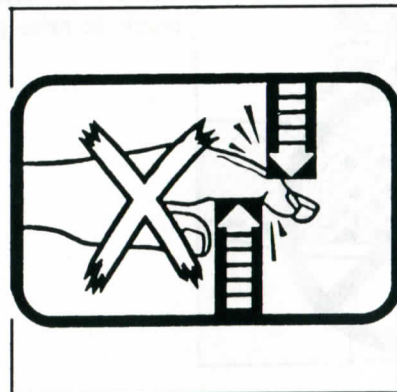

19341

46. Located on the upright tie bars are safety decals. The decal found in Fig. 19341 (above) is a warning to avoid placing your hands through the upright.

Operator's Compartment & Controls

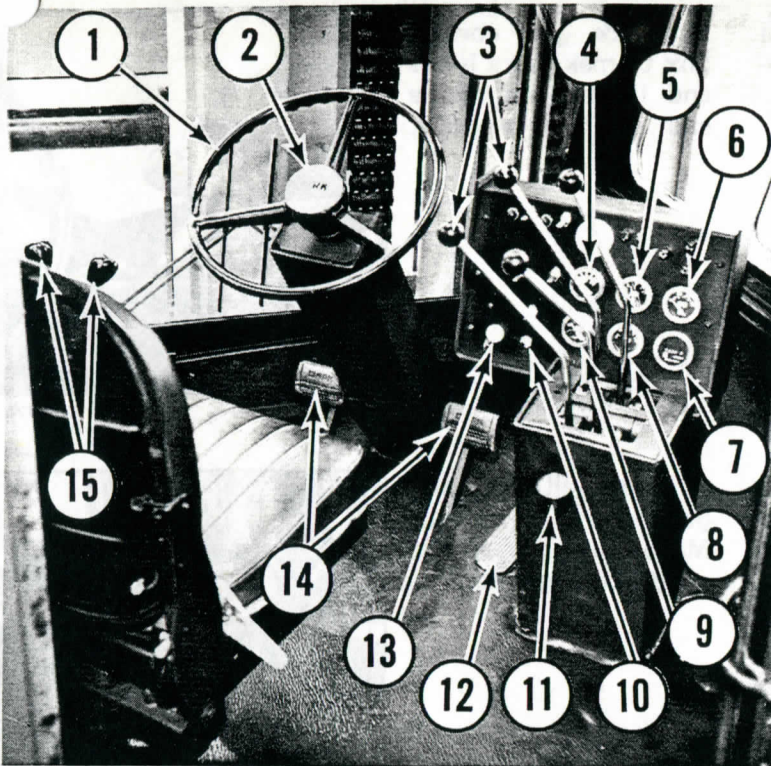

1. Steering Handwheel
2. Horn Button
3. Control Levers for Tilt, Lift and Auxiliary Hydraulic Functions.
4. Voltmeter
5. Fuel Gauge
6. Converter Oil Temperature Gauge
7. Hourmeter
8. Engine Oil Pressure Gauge
9. Water Temperature Gauge
10. Cold Start Button
11. Oil Filter Pressure Indicator Gauge
12. Accelerator Pedal
13. Ignition Switch
14. Brake Pedal and Inching-Brake Control Pedal
15. Transmission Directional and Speed Control Levers.
Parking Brake Left of Seat.

A1376

C500 Y800

Compartment & Controls

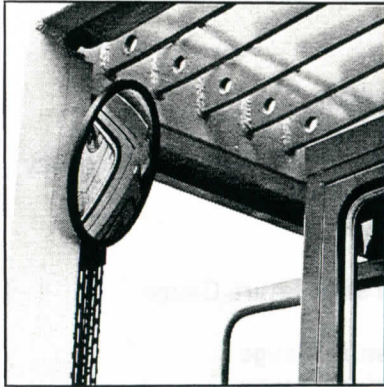

A1400

1. Adjust the mirror(s) to proper angle for unobstructed view.

2. Check gear control box to make sure levers and linkage are secure and working properly.



A1378

A1393

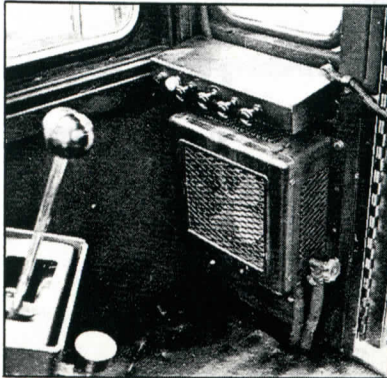

3. Check the heater to make sure the fan and all controls function properly. Also, check windshield wipers. The control knobs are located just above the heater and fan.

4. Check all fuses and gauges for damage. Make sure all are in good working order.

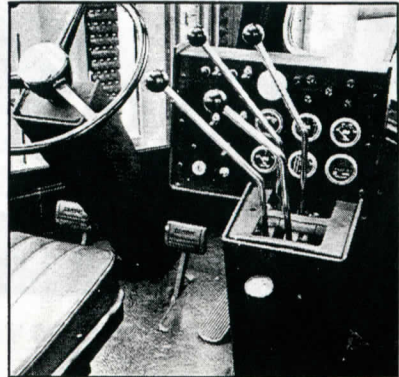

A1395

Before Operation

(On The Ground Checks)

1. Each shift operator must complete an operator's daily check list (available from your Clark Dealer). Make all checks listed and give completed check list to designated authority.

2. Walk around truck and visually check for damage and leaks. Note all damage and leaks on check list.

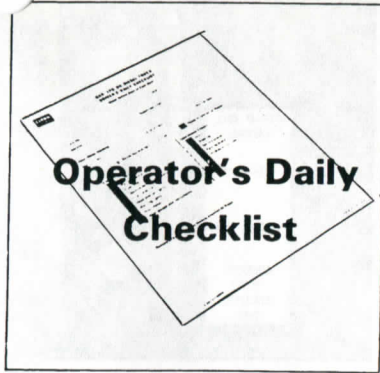

15197

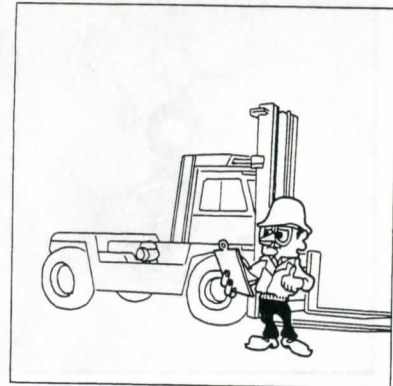

19339

13633



3. Check condition of all drive and steer tires and wheels.

Remove foreign material such as stones, cinders, nails, etc., which have become lodged in tire treads.

Note apparent tire or wheel damage on check list.

4. Visually check drive and steer wheel mounting nuts.

Report any apparent loose lugs or nuts to designated authority.

Torque specs for wheel lugs and nuts are listed in the appropriate PMA manual for your truck model.

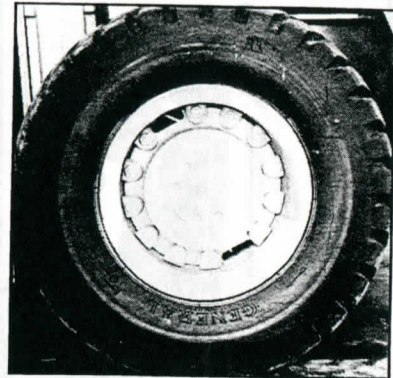

13634

Before Operation

(On The Ground Checks)

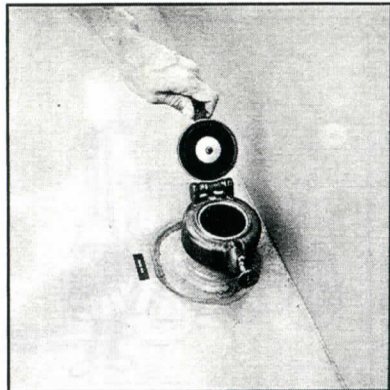

A1396

5. Your truck is diesel powered. Check fuel screen for damage and keep it clean.

6. Check sump sight gauge to make sure sump tank is at proper level.

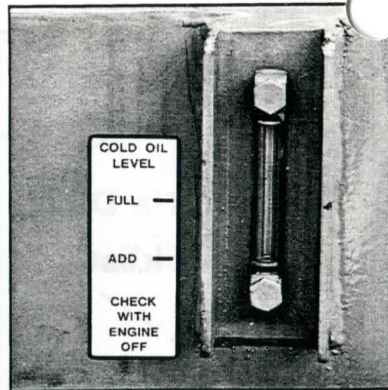

A1364

A1384



7. Check condition of overhead guard.

Make certain that it is secure and undamaged prior to operating the truck.

8. Remove blocks from drive wheels and carefully climb steps into the operator's compartment.



A1385

Before Operation

(Maintenance Checks)

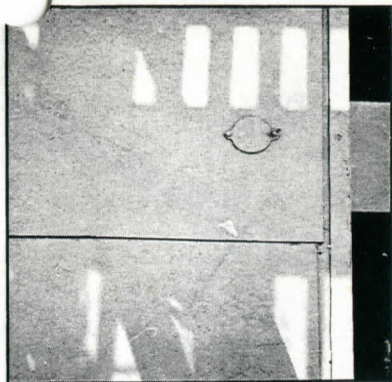

A1401

9. Check overall condition of deck plates. Make sure they are in place.

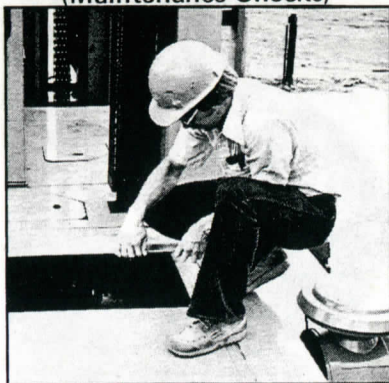

A1003

10. Only when necessary, remove deck plates to expose engine compartment.

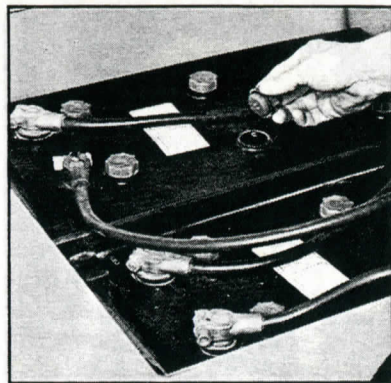

A0925

11. Check the condition of the batteries, battery terminals, cables, etc., and note anything unusual on your check list.

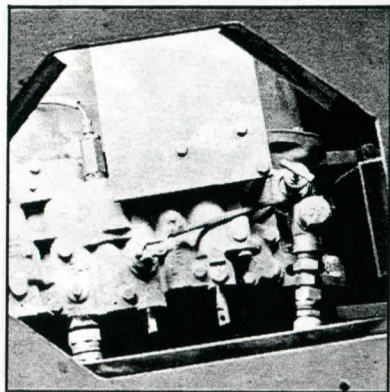

A1022

12. The transmission fluid is checked by removing a deck plate located behind the cab. With the engine running in neutral, pull the dipstick and wipe. Insert dipstick into support tube all the way. Then remove and check for proper level.

Before Operation (Maintenance Checks)

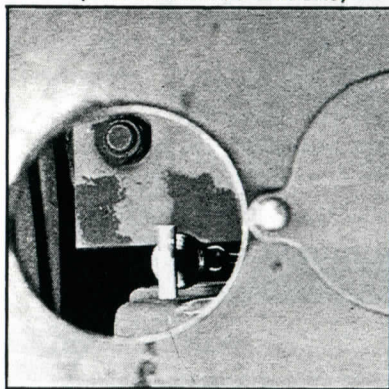

A1017

13. The engine oil dipstick is located as shown above. Pull the dipstick and wipe it with a clean, lint free cloth. Insert dipstick into support tube all the way – then pull the dipstick out again and check oil level as described in item 14. Replace the dipstick.

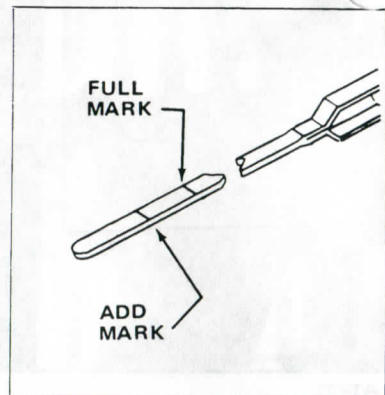

13239

14. Engine oil level must be maintained between the "add" and "full" marks on the dipstick. The best time to check oil level is before starting the engine or, as the last item on the check list. This allows oil to drain back into the crankcase. Remember – one quart of oil will raise the level from "add" to "full" – DO NOT OVERFILL.

Before Operation

(Maintenance Checks)

15. Always check radiator coolant level with the engine turned off and, when possible, with engine cold. Proper coolant level is one inch below the bottom of the filler neck.

CAUTION: Use extreme care when removing radiator pressure cap. The sudden release of pressure can cause a steam flash resulting in serious injury. Place a rag over cap and loosen slowly to allow gradual escape of steam.

Never add cold water or anti-freeze to the radiator of an overheated engine. Always allow the engine to cool to avoid the danger of cracking the cylinder block or head(s). Keep engine running when adding water or anti-freeze. A solution of 50% ethylene glycol and 50% water is recommended. **NEVER USE ONLY WATER.**

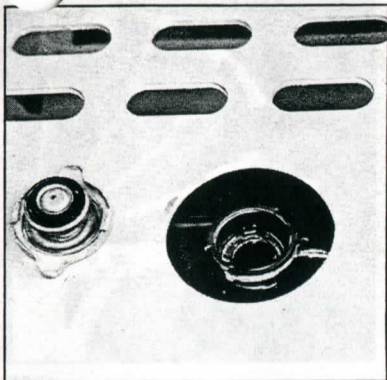

A1019

A1003

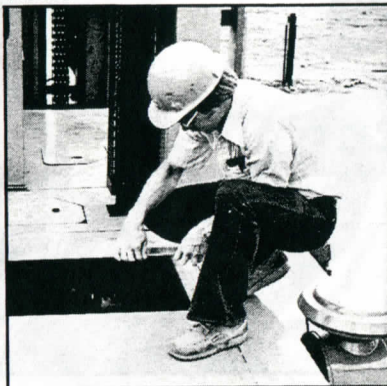

16. Make sure all caps, dipsticks, deck plates etc. are in proper position. Then seat yourself in the operator's seat.

17. Your truck has been equipped with an operator's cab. Check condition of all glass. Clean all dirty glass and mark your check list to indicate any cracked or broken glass.

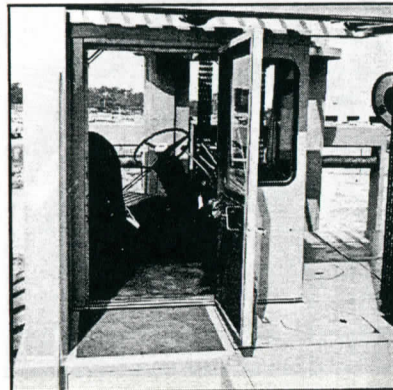

A1380

Before Operation

(Starting the Engine)

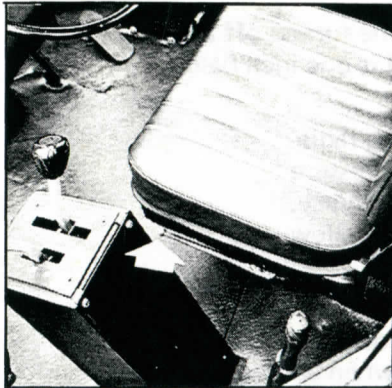

A1402

A0945

18. Seat adjustment is accomplished by releasing short lever at right side or left front of seat.

Adjust operator's seat to position which is comfortable for you and provides easy access to all hand and foot controls.

Make sure seat locks in selected position.

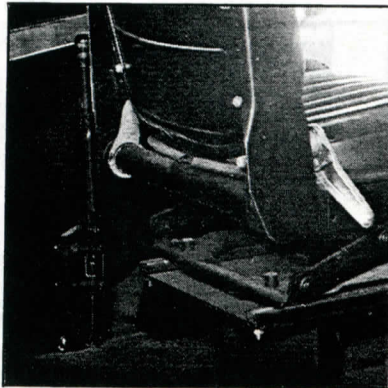

20. The parking brake should be adjusted to hold the truck while in second gear and engine at governed R.P.M.

19. Make certain that the parking brake lever is in the "on" (full-up) position. Brake holding power can be adjusted by rotating the knob on top of the lever clockwise to increase hold power or counterclockwise to reduce it.

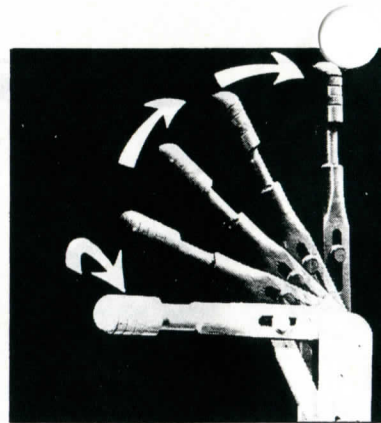

13228

A1378

21. Make certain that transmission directional control lever is in neutral.

This truck is equipped with a neutral start switch and should not start while in forward or reverse.

Report condition on your check list.



Before Operation

(Starting the Engine)

22. Insert key into ignition switch and turn key clockwise to "run" position.

Check the fuel gauge to determine the amount of fuel in the tank.

Never attempt to start a diesel engine on an empty or near empty tank.

23. Place your right foot on the accelerator pedal and press down slightly.

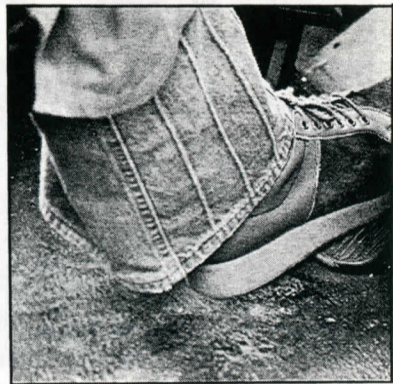

A1403



13220

13226

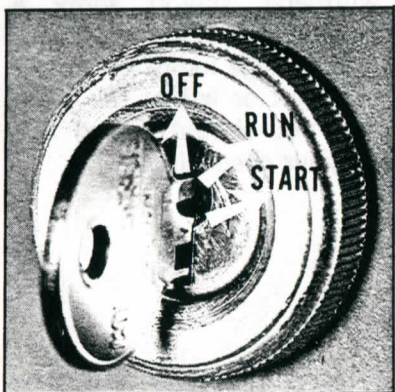

24. Turn ignition switch key clockwise to the "start" position.

Release key to "run" position when engine starts.

If engine does not start on the first attempt — do not re-engage the starter until engine comes to a complete stop (approximately 5 seconds.)

25. Check the engine oil pressure gauge to insure that it is undamaged and that it is functioning properly.

If engine oil pressure drops below 5 P.S.I. or becomes erratic during truck operation you should immediately shut the engine down until the cause is located and corrected.



13222

Before Operation

(Instrument Check)

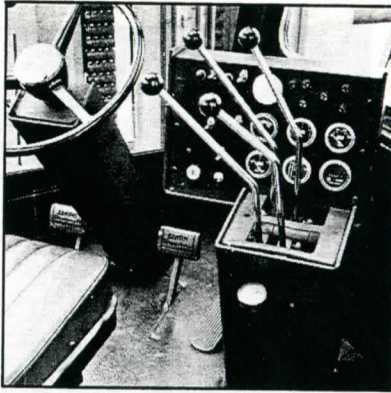

A1395

26. You must learn the location and function of all your trucks, gauges and instruments.

They should be checked, from time to time, during operation of your truck.

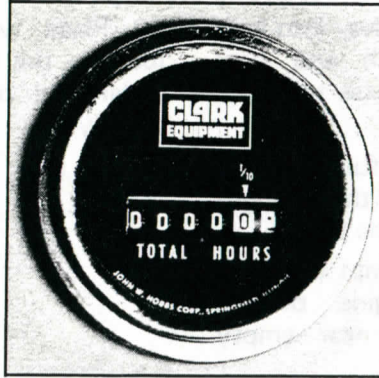

13225

27. Check engine hour meter to insure that it is undamaged and that it is functioning properly.

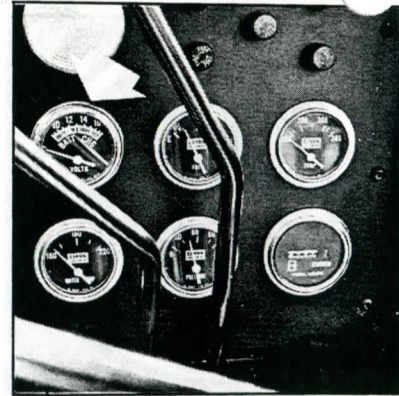

A1377

28. With engine running the voltmeter should show a reading within the green arc. If the gauge indicates a reading right or left of the green arc, you should record this on your check list.

Before Operation

(Instrument Check)

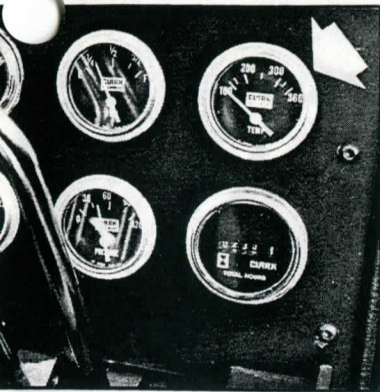

A1381

A1388

29. Check converter oil temperature gauge to insure proper function.

30. Check the water temperature gauge to insure that it is undamaged and functioning properly.

Water temperature should reach about 180°F. after 10 minutes of operation. If the indicator needle goes into red area, you should immediately shut the engine down until the cause is located and corrected.

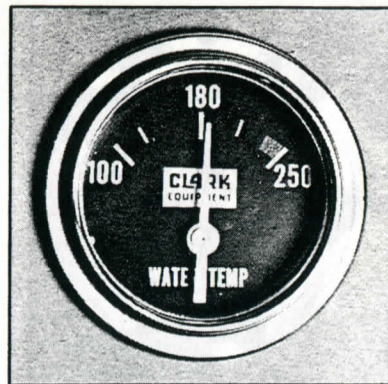

13223

A1404

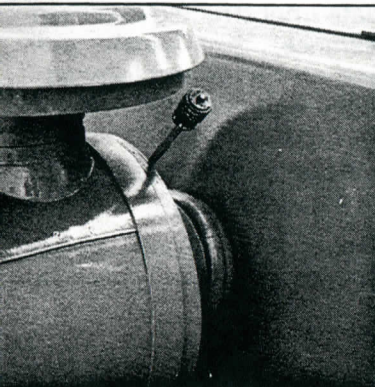

31. All truck models are equipped with an air cleaner condition indicator. With engine running at governed R.P.M., if the indicator registers red, the air cleaner must be serviced. The indicator may be reset by pushing the button on the indicator.

32. In order to check hydraulic oil filters, start the engine and operate near governed R.P.M. If the oil filter gauge indicates pressure in the red area, the filters should be changed.

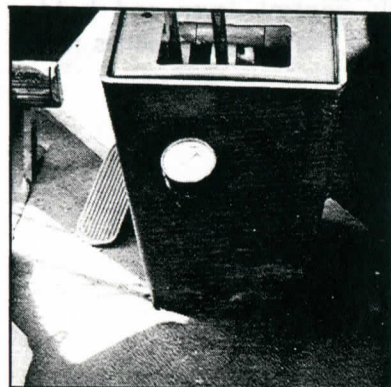

Before Operation

(Hydraulic Controls Check)

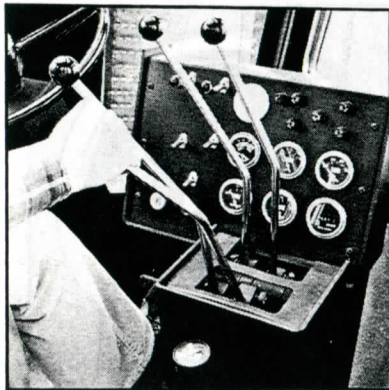

A1405

33. Gently pull back on the tilt control lever and hold until the upright reaches full back tilt.

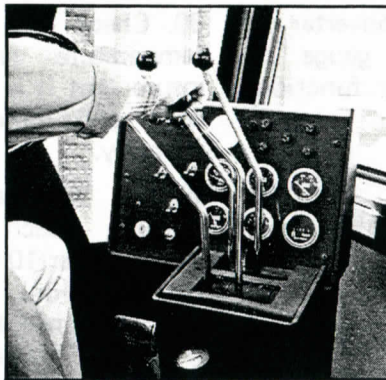

A1406

34. Push tilt control lever forward and hold in position until upright tilts forward to near vertical position.

Releasing tilt control lever will halt forward tilt at desired point.

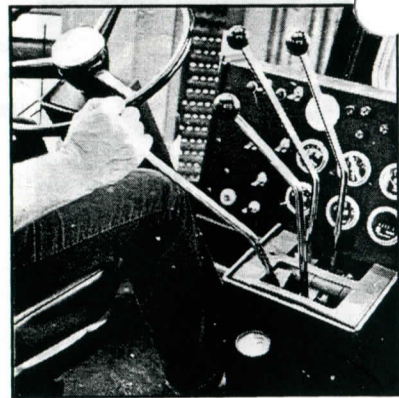

A1382

35. Carefully check for adequate unobstructed overhead clearance, then gently pull back on lift control lever and hold until upright reaches maximum lift height.

Release lever to halt upright lift at desired point.

Note any erratic upright operation to your check list.

Before Operation

(Hydraulic Controls Check)



A1383

36. Push lift control forward. Hold while closely observing descent of upright.

Release lever to stop upright descent near (about 8 inches) ground level.

Record any erratic or unusual operation on your check list.

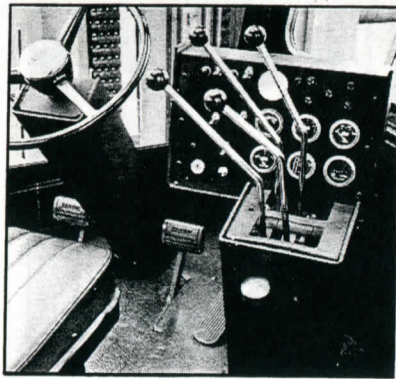

A1395

37. This truck when equipped with hydraulic attachments or accessories will use the same control levers.

The function of these lever(s) should be checked with your supervisor prior to attempting operation thereof.

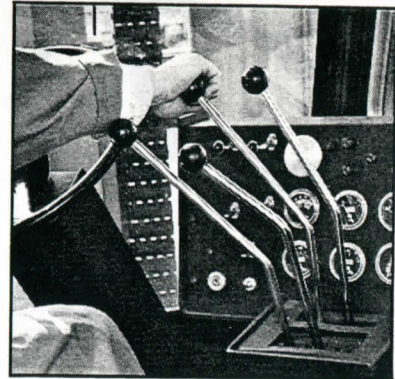

A1407

38. The two forward levers are used for hydraulic function of spreading the forks. Pull back lever for right hand movement and push forward for left hand movement. Never use this operation with a load on the forks.

Before Operation

(Horn & Steering Check)

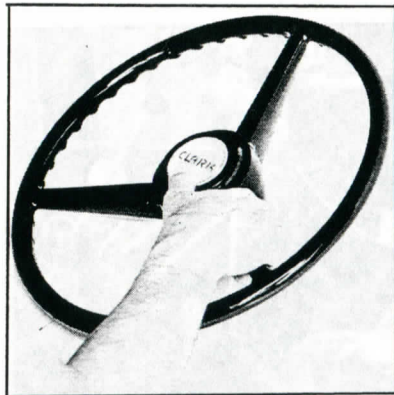

13141

39. Press horn button to determine if horn is operational.

If horn does not function properly record it on your check list and report it to the designated authority when you have completed your "before operation" checks.



A1389

40. With the engine running you should rotate the steering handwheel back and forth.

Check for excessive effort to turn the handwheel and make certain that steer wheels respond to movement of the handwheel.

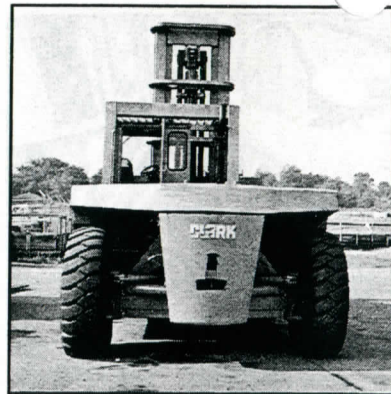

A1390

41. Check all around truck to make sure that your desired path of travel is unobstructed.

Before Operation

(Transmission Controls Check)



A1392

42. Place your right foot on the brake pedal and press down firmly to apply the service brakes. The brakes are power actuated. If the power fails, the truck can be stopped with increased pedal effort.

43. Your truck is equipped with a hydraulic transmission. To start truck in motion you must use first gear. While in motion, if your operation does not require first gear, you can shift to second, third or fourth gear.

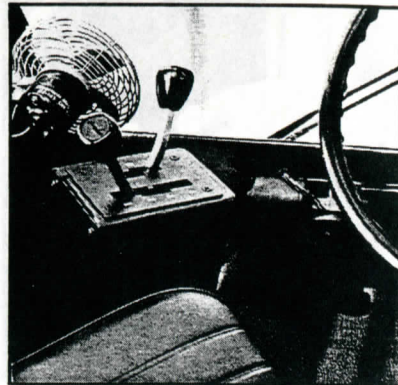

A1397

A1397

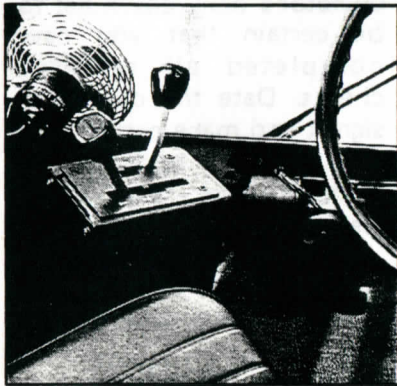

44. Shift directional selector lever into position for desired direction of travel. Pull the lever back for reverse travel (or push the lever forward for forward travel).

45. Place transmission directional (forward-reverse) selector lever in neutral position, apply parking brake, lower upright to place forks on (or near) the ground and push tilt control lever forward until fork tips rest on the ground.

A1383



Before Operation

(Check List Completion)

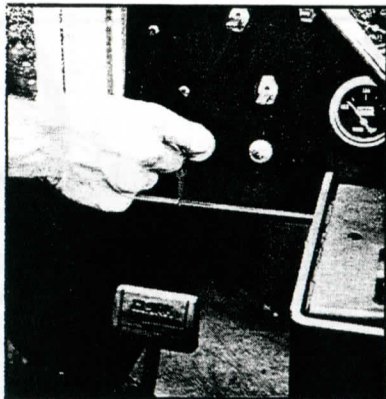

A1386

46. Make certain that all transmission controls are in neutral, the upright is lowered, tilted forward with fork tips on the ground, the parking brake lever is in the "on" position and that you have removed the key from the ignition switch.

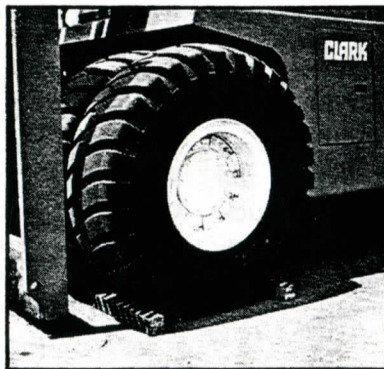

A1387

47. Carefully dismount from the truck.

Leaving a truck on an incline is never recommended. If it becomes necessary to leave your truck in this position make certain that the drive wheels are securely blocked to prevent roll.



15197

48. Carefully review your operator's daily check list to be certain that you have completed all required checks. Date the check list, sign it and make certain that it is turned in to the proper authority per your supervisor.

Operating Hints



A1378

1. (A) This model must be brought to a complete stop before shifting the directional control lever from forward to reverse or from reverse to forward.

(B) Use of low gear when starting, negotiating grades or ramps, and when operating over rough or unimproved surfaces is recommended.

(C) Transmission speed ranges may be changed while traveling. Also, the transmission is automatically disengaged when either brake pedal is fully depressed. For smooth starts, the engine should be at a low R.P.M. before releasing the brakes. When the brakes are released the transmission reengages the same gear as when first disengaged.

CAUTION: Always come to complete stop before shifting to low gear.

(D) Selecting the correct drive gear ratio is an important operator's function. Choosing the proper gear will result in better truck performance with longer engine and transmission life.

(E) If the operating surface is rough, or soft, or if grades or ramps must be negotiated, use the lowest transmission gear ratios available to you because — here power is needed — speed is not.

(F) As a general rule of thumb — **DO NOT** lug the engine. Overworking the engine through use of a "too high" gear ratio will create excessive heat and shorten component service life. When in doubt — use next lower gear.

Operating Hints

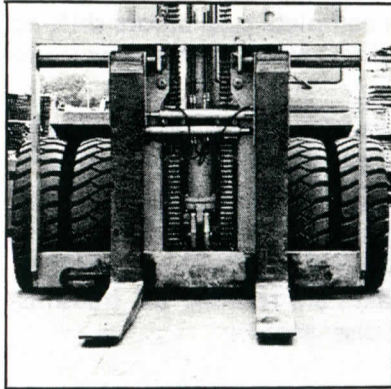

A1408

2. Lift forks should be adjusted on the hanger shafts to obtain maximum support and balance of the load.

3. Remember to approach load slowly and squarely to avoid damaging the material being handled and to minimize truck maneuvering.

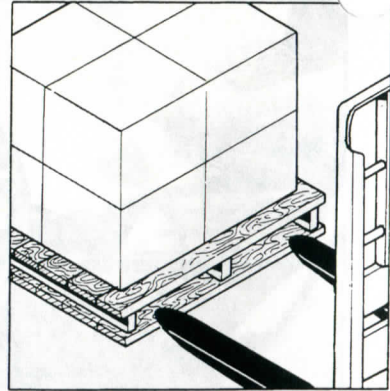

13203

A1389



4. Be constantly alert for abrupt changes in the operating characteristics of your truck. Unusual noises or sudden changes should be reported to your supervisor immediately.

5. Required adjustments and/or repairs should be performed by thoroughly trained and qualified personnel only.

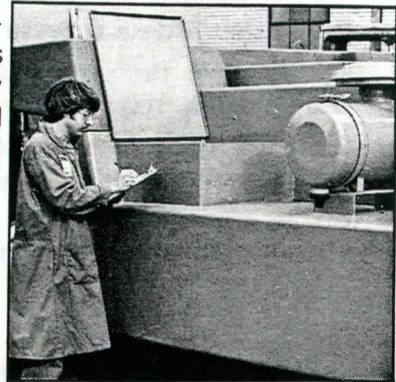

A1399

Parking

1. Park lift trucks in designated parking areas only.

Do not block aisles, exits, entrances or other emergency lanes.

2. Make certain that transmission controls are in neutral and that parking brake has been properly applied.

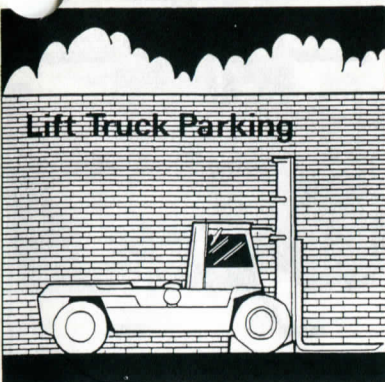

19333

A1398

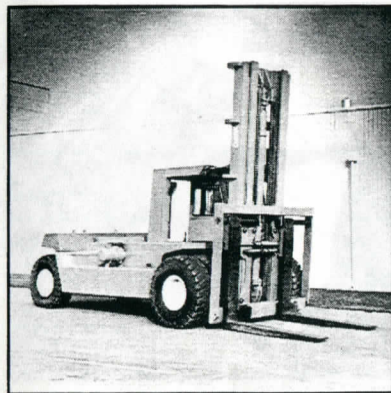

Code: OI-416 October 78



A1378

A1387

3. Lower upright to point where lift forks are on, or near, the operating surface and tilt upright forward so that fork tips touch the operating surface.

4. Stop engine, remove key, dismount carefully and securely block drive wheels.



Page 33

Helpful Hints

TIRE PRESSURES		
Tire Size	Ply	P.S.I.
100 x 25	24	95
1800 x 25	32	110

When adjusting fork spread, tilt upright slightly forward. This will reduce friction and make slide action easier.

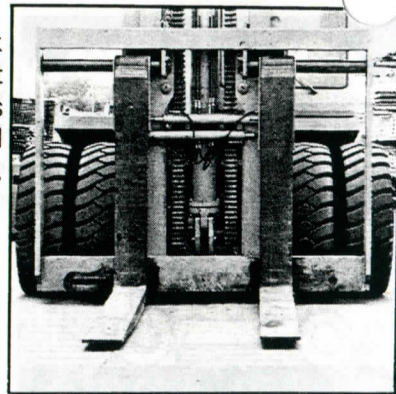

A1408

A1394

A1391

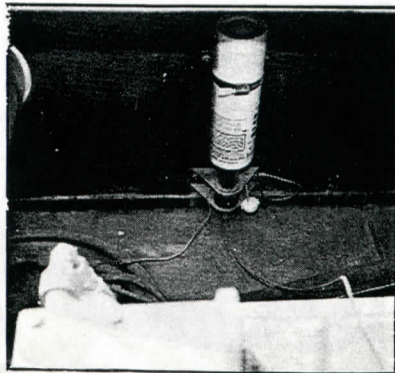

A cold weather starting device is standard equipment for the Cummins diesel engine. Follow this procedure:

- Unscrew cap from body and screw on ether bottle.
- Turn key on and push ether button once. (See Fig. A1394)
- Fully depress accelerator pedal; engage the starter.

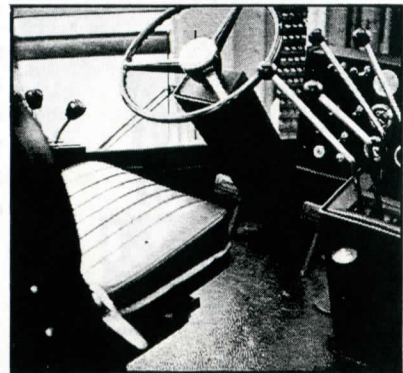

Helpful Hints

SERIES 3

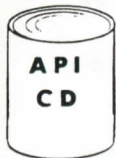

MIL-L-45199B
MIL-L-2104C

For . . . diesel engines using high sulfur content fuel (over 0.5% sulfur).

SPECIFICATION To meet API Service Classification "CD" per SAE Report J183 and equivalent Series 3 and/or MIL-L-45199B specifications. Also MIL-L-2104C when applicable. Sulfated ash content 1.65% maximum.

TYPICAL PRODUCT RECOMMENDED BY MAJOR BRAND OIL SUPPLIERS

Chevron DELO Super 3 Oil
Shell Rimula Motor Oil
Sunfleet S-3 Motor Oil
ARCO Fleet MS-3 Motor Oil
Gulf Super Duty Motor Oil
AMOCO 300 Motor Oil
Citgo C500 Motor Oil
Texaco URSA LA-3 Motor Oil
Mobil Delvac 1300 Series Motor Oil
. . . or the equivalent to the above.

• ENGINE CRANKCASE OIL

RECOMMENDED SAE VISCOSITY NUMBER

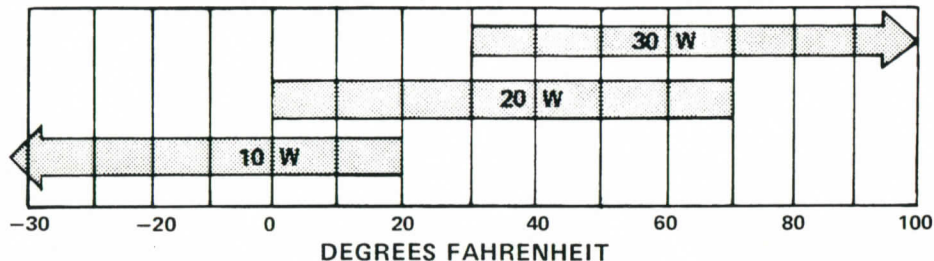

Helpful Hints



DIESEL

SPECIFICATIONS Fuel to be Automotive Quality Diesel Fuel Oil as defined by ASTM D975, Grades No. 1-D and 2-D, and having a sulfur content of less than 0.5% weight.

Recommended Cetane
Number — 45 Minimum

Shell Premium Dieseline OR45
Sun Diesel Fuel 245-T
ARCO Premium Diesel, Diesel #1 or #2
Gulf or Citgo Diesel Fuel #1 or #2
AMOCO Diesel Fuel #1D and American
Premier Diesel Fuel #2D
Texaco Diesel Chief #1
Mobil Fuel Diesel & Diesel Fuel Special
... or the equivalent to the above.



For Handy Reference

RECORD THE FOLLOWING INFORMATION PERTAINING TO YOUR TRUCK

Model No.

Serial No.

Attachments

Truck Weight (Empty)

Truck Rated Capacity

Gross Vehicle Weight (With Rated Load)

Transmission Type

Fuel Type (Diesel)

Tires (Pneumatic)

Type Controls (Console or Column Mounted)

Customer Truck Identification



Additional copies of this manual may be purchased from
YOUR AUTHORIZED CLARK DEALER.

CLARK[®] Material Handling
Company

Lexington, KY 40507
Printed in USA