

---

# Operator's Instruction Manual

---

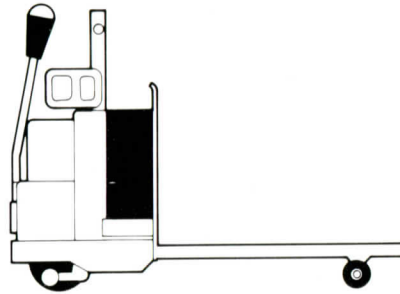

HWP 40 thru 60

---

**CLARK**

Book No. 2385908  
OI-347, 3rd REV.



# **WARNING**

**FOR YOUR SAFETY AND THE  
SAFETY OF OTHERS**

**BEFORE YOU OPERATE THIS TRUCK!**

**READ ALL WARNINGS AND INSTRUCTIONS IN THE  
OPERATOR'S MANUAL AND ON THE TRUCK.**

**CHECK THE TRUCK FOR CORRECT OPERATION.**

**DO NOT OPERATE THIS TRUCK UNLESS YOU ARE  
TRAINED AND AUTHORIZED TO DO SO.**

## FOREWORD

Federal and state laws require that operators be completely trained in the safe operation of lift trucks.

Before you start operating this lift truck, make sure that you understand all driving procedures. It is important to operate your lift truck safely and efficiently.

This manual will help you learn how to operate your lift truck. This manual describes the controls, special features and the functions of each control.

This manual is not a training manual, it is a guide to help authorized operators safely operate a lift truck. Illustrations in this manual show the operator correct procedures for checking, starting, operating and stopping the lift truck.

Clark lift trucks are built to take hard work, but not abuse. They are built to be dependable but as with any lift truck, they are only as efficient as the operator and the persons responsible for maintaining them.

Do not make any repairs to this lift truck unless you have been trained in lift truck repair procedures and authorized by your employer.

MANUALES DE INSTRUCCIÓN PARA OPERADORES IMPRIMIDOS EN ESPAÑOL SON OBTENIDOS DE SU DISTRIBUIDOR CLARK.

BETRIEBSANWEISUNGEN IN DEUTSCHER SPRACHE KOENNEH SIE BEI IHREM CLARK-HAENDLER ERHALTEN.

MANUELS DE L'OPERATEUR EN LANGUE FRANCAISE PEUVENT ETRE COMMANDES CHEZ VOTRE DISTRIBUTEUR CLARK.

# TABLE OF CONTENTS

Operator's Warning .....	Page i
Foreword .....	Page ii
Drive Safely .....	Page iv
Summary of Safe Operating Practices .....	Page v and 1
Major Component Identification .....	Page 2
Safe Operating Rules and Practices .....	Pages 3 thru 13
Operator's Compartment and Controls .....	Page 14
Operator's "Before Operation" Checks .....	Pages 15 thru 22
Operation .....	Pages 23 thru 27
Parking Procedures .....	Page 28
Handy Reference Data .....	Page 29



# **DRIVE SAFELY**

**BEFORE YOU OPERATE THIS LIFT TRUCK, READ AND UNDERSTAND THE INSTRUCTIONS, SIGNS AND MESSAGES IN THIS MANUAL AND ON THE LIFT TRUCK.**

**INJURY OR DEATH TO YOU OR OTHER PERSONNEL WILL OCCUR IF YOU DO NOT FOLLOW THESE INSTRUCTIONS AND MESSAGES.**

**STAY ALERT!**

# SUMMARY OF SAFE OPERATING PROCEDURES

1. Do not operate this truck unless you have been trained and authorized to do so. Read all warnings and instructions in operator's manuals and on this truck.

2. Do not operate this truck until you have checked its condition. Give special attention to Tires, Horn, Lights, Battery, Controller, and Lift Systems including forks, limit switches, brakes, steering mechanism, and guards.

3. Do not operate the truck with wet or greasy hands.

4. Do not handle loads which are higher than the load backrest unless load is secured so that no part of it could fall backward.

5. Do not handle unstable or loosely stacked loads. Use special care when handling long, high or wide loads to avoid losing the load, striking bystanders, or tipping the truck.

6. Do not overload truck. Check capacity plate for load weight information.

7. Start, stop, travel, steer and brake smoothly. Slow down for turns and on

uneven or slippery surfaces that could cause truck to slide or overturn. Operate carefully when traveling without a load as the risk of overturn is greater.

8. Travel with load or lifting mechanism fully raised. Look in the direction of travel and operate the truck so that the load does not interfere with your view.

9. Operate carefully on ramps, travel slowly and do not angle or turn. Always operate on ramps with load end downhill.

10. Observe applicable traffic regulations. Yield right-of-way to pedestrians. Slow down and sound horn at cross aisles and wherever vision is obstructed.

11. Before lifting, be sure load is centered and forks are completely under load.

12. Do not put any part of your body under the forks or load.

13. Do not lift or travel with personnel on the forks.

14. Do not permit passengers to ride on the truck.

15. Make sure your truck is the correct fire safety type, and approved, for the area in which you are working. The correct type designation for the truck is on the nameplate. If unsure of the classification of the area you wish to enter, ask your supervisor before entering.

16. Before driving over a dockboard or bridgeplate, make sure it is secure. Drive carefully and slowly, and do not exceed its rated capacity.

17. Do not run over any objects as truck stability could be adversely affected.

18. Only authorized and qualified persons should make repairs and adjustments to the truck.

19. Report all accidents involving personnel, building structures, and equipment to the correct authority.

20. Foot protection (safety shoes) must be worn. Keep feet away from truck frame and wheels.

21. Keep hands and fingers inside the protected area of the control handle when traveling or turning.

# **SUMMARY OF SAFE OPERATING PROCEDURES (Continued)**

22. Use caution when traveling with load end leading due to drive end swing when turning.

23. Use caution when turning with load end trailing. The load wheels tend to "cut" the corners.

24. Put both hands on the control handle when operating with the load end leading.

25. Enter elevators or other confined areas with the load end leading.

26. When possible, walk ahead and to the side of the control handle when traveling with load end trailing. Operate with one hand on control.

27. Allow adequate space for maneuvering truck when withdrawing from a stack.

28. Before leaving the truck, make sure the control handle is fully raised, the lifting mechanism is lowered, and the key (if equipped) is turned to the 'OFF' position.

## Know Your Truck

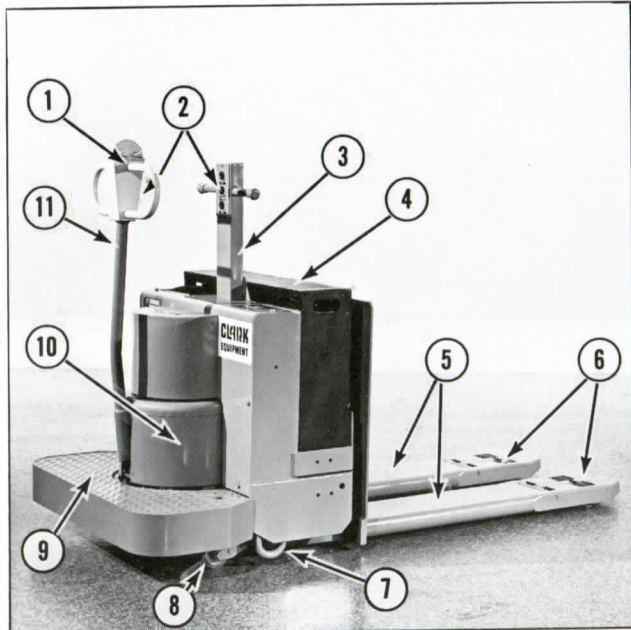

15196

HWP-40 and HWP-60  
Hi-Speed, Warehouse, Pallet Truck  
4000 Lbs. and 6000 Lbs. Rated Capacities

1. Directional and Speed Control Levers.
2. Horn, Lift, Lower and High Speed Controls.
3. T-Bar Support Handle.
4. Battery.
5. Pallet (load) Forks.
6. Load Wheels and Tires.
7. Skid Runner.
8. Spring Loaded Caster (optional).
9. Rider Platform.
10. Drive Unit Cover.
11. Steering and Brake Control Handle.

## Safety

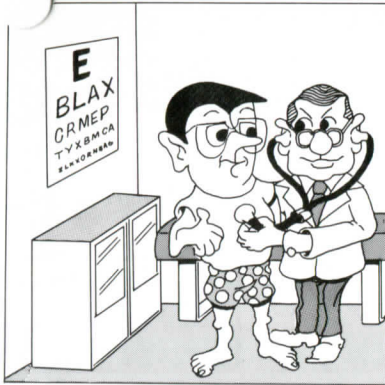

13696

15015

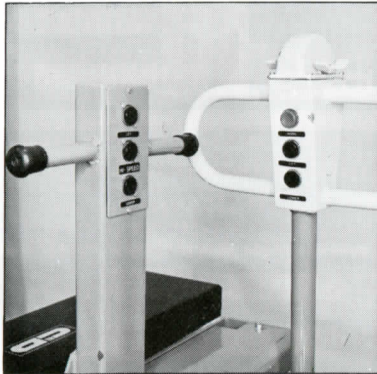

Code: OI-347, Rev. Apr. 84

1. Only physically qualified and thoroughly trained personnel shall be authorized to operate the Clark (walk/ride) HWP-40, or HWP-60 model trucks.

3. Learn how your truck is operated. Know its safety devices; how they function and how your truck's special attachments (if any) work.

2. Prominently placed on every Clark truck is a list of basic rules for operation. These rules are for the protection of you and others in your operating area. Be familiar with them.

4. Never operate a "walk/ride" type truck with wet or greasy hands or shoes.

### ! WARNING

**BREAKING THESE RULES WILL CAUSE SERIOUS OR FATAL INJURY TO YOURSELF AND OTHERS.**

- Do not operate this motorized hand truck unless you are trained and authorized. Read and understand the operator's manual before starting truck.
- Do not operate damaged or faulty truck. Do not attempt repairs unless you are trained and authorized.
- Keep hands on designated grips and feet away from truck. Do not operate truck with wet or greasy hands or shoes.
- Enter confined areas with load end first. Be very careful when operating in confined areas to avoid being pinned.
- Avoid uneven or slippery surfaces and loose materials.
- Travel slowly and with caution on slopes and do not turn. Always travel with load end down grade.
- Do not load truck over capacity on nameplate. Do not handle shaky loads. Be very careful when handling long, high or wide loads.
- Do not exceed floor weight limits.

Clark Equipment Co. 1983      Paper Truck      2377862

24975

13868

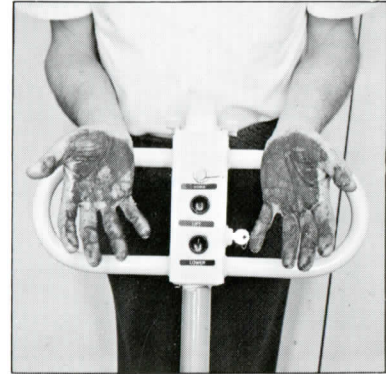



# Safety



15198

5. Wearing safety glasses, "hard hat" and safety shoes is recommended when operating the HWP (walk/ride) model trucks.

Dress suitably and avoid wearing loose fitting clothing.

15016



7. Look all around truck before moving it in any direction.

Once certain that your desired path of travel is unobstructed, remember to start and stop truck slowly and smoothly.

6. Before operating any HWP (walk/ride) type truck check steering, horn, brake application, forward-reverse switch, lift and lower controls for proper operation.

Faulty or erratic performance must be reported immediately.

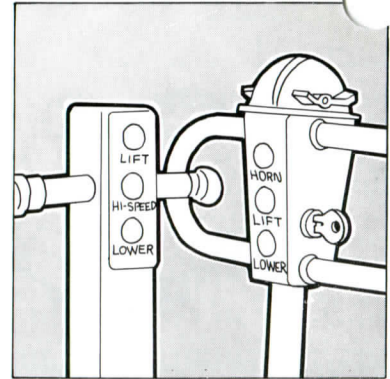

15199

15200

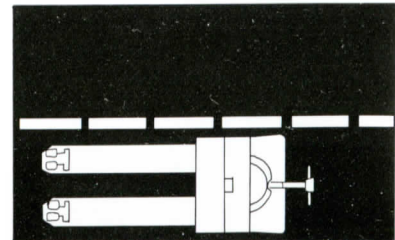
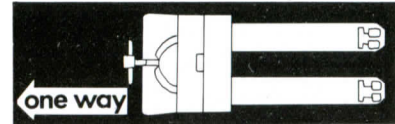

8. Operate trucks only in designated truck routes and keep operating aisles clear.

One-way aisles are recommended. If this is not practical in your operation heed highway traffic regulations and keep to the right of aisle centerline.

## Safety

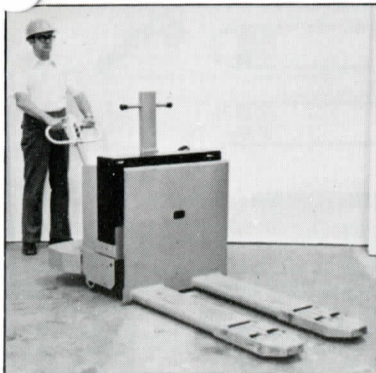

15017

9. Always be alert for pedestrians, other trucks or obstructions in your path of travel.

10. When operating the HWP (walk/ride) model trucks remember to sound the horn at all corners, exits, entrances and when approaching pedestrians.

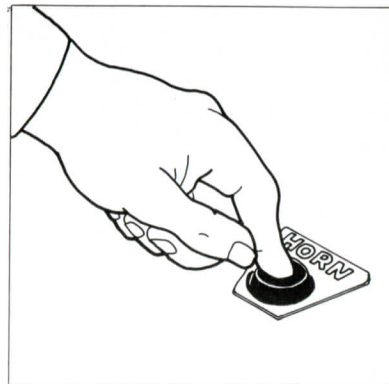

13085

13087



11. Obey all plant traffic rules and warning signs.

12. Maintain a safe distance from the truck ahead of you at all times.

Assure ample distance to stop smoothly and safely should the need arise.

15201



## Safety



15202

13. Be careful of drive end swing when turning while operating the truck in reverse.

Carelessness may result in damage to material or equipment in your operating area and/or to the drive end of your truck.

15203



15. Be extremely cautious when operating the HWP (walk/ride) model trucks near the edge of a loading ramp or dock.

14. Use caution when making right or left turn into aisle. Remember that the load wheels do not follow the turn path of the drive wheel. They tend to "cut" the corner.

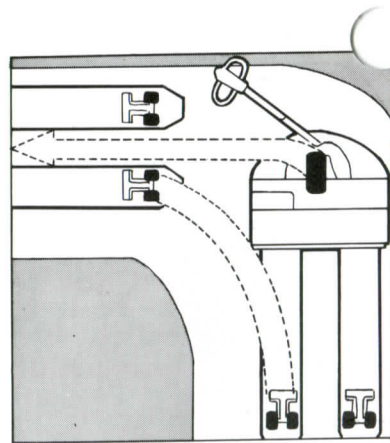

14689

15204

16. Never use your truck to push or tow another. Never allow your truck to be pushed or towed by another.

Should a truck become disabled and require moving, notify the proper authority immediately.





## Safety

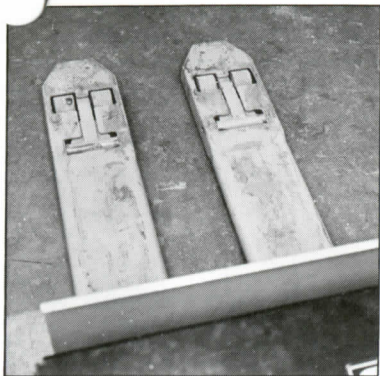

15018

17. Be aware of the position of your fork tips at all times.

Be alert to avoid striking anything with the fork tips.

18. Make certain that vehicle being entered has been adequately blocked to prevent accidental roll. Bridge plates must have adequate strength, width, guard rails each side (minimum 3" high recommended) and be properly secured.

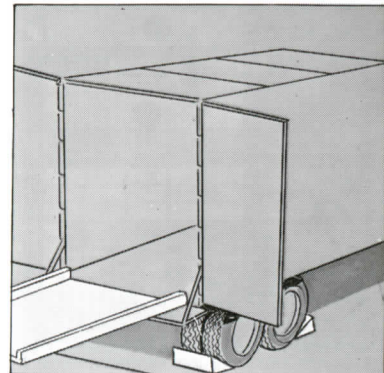

13146

15205



19. Trucks of this type are designed to be controlled primarily by a walking operator.

Rider operation of these trucks is permissible but is recommended only on long straight warehouse runs.

Never indulge in horseplay while operating these trucks.

20. Never carry unauthorized personnel.



15206

# Safety

**CLARK EQUIPMENT**

INDUSTRIAL TRUCK DIVISION BATTLE CREEK MICH

MODEL NO. \_\_\_\_\_ SERIAL NO. \_\_\_\_\_ TYPE \_\_\_\_\_

ATTACHMENTS \_\_\_\_\_

LOAD \_\_\_\_\_

CAPACITY WITH ATTACH. LISTED ABOVE OR WITH FORKS UPRIGHTS VERTICAL

	B	A	B	C
5				

FLOOR \_\_\_\_\_

APPROX. WT. ALL TRUCKS \_\_\_\_\_

APPROX. WT. ELECTRICS ONLY \_\_\_\_\_

BATTERY WT. \_\_\_\_\_

BATTERY CAPACITY \_\_\_\_\_

LESS BATT. ELECTRICS

WITH MAX. BATT. WT.

MAX. _____	MIN. _____
AH _____	NO. _____
LEBS _____	VOLTS _____

FOR OTHER CAPACITIES CONSULT MANUFACTURER AS RELEASED FROM FACTORY THIS TRUCK MEETS THE DESIGN SPECIFICATIONS ESTABLISHED IN AMERICAN NATIONAL STANDARD FOR POWERED INDUSTRIAL TRUCKS; PART II, ANSI B 56.1-1969. PT. NO. 2335709

13095

15207

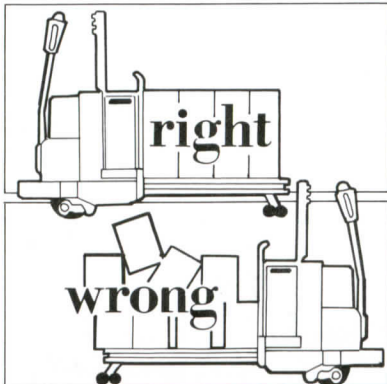

Page 8

21. Know the rated capacity of your truck and its attachment (if any) and never exceed it.

Study your truck data-capacity plate and learn the facts stamped in areas 1 through 8.

22. Thoroughly inspect load to be moved for overload and/or poor balance. If the safety of the load is questionable . . . Don't Move It.

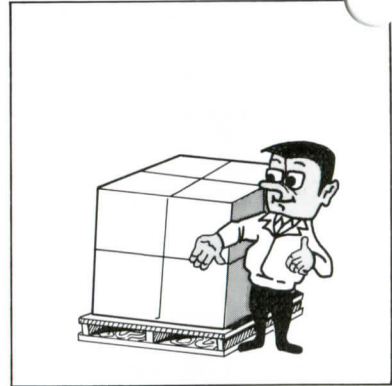

13094

13872

23. Unstable loads are a hazard to you and to your fellow workers. Always make sure that your load is well stacked and evenly positioned across both forks.

Never attempt to lift a load with only one fork.

24. Check to insure that you have adequate unobstructed clearance before attempting lift.

Press firmly on "lift" button and hold until load reaches full elevation. Release button to stop load lift at desired level.

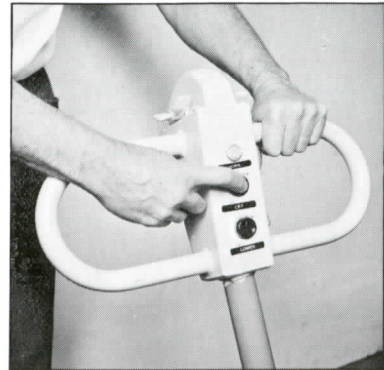

Code: OI-347 Aug 74

## Safety

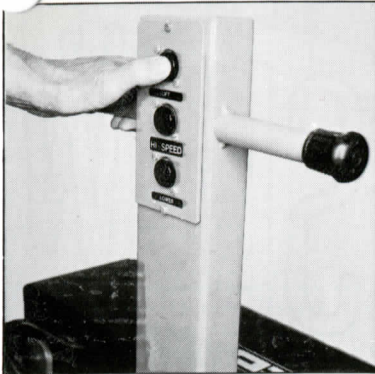

15020

15209

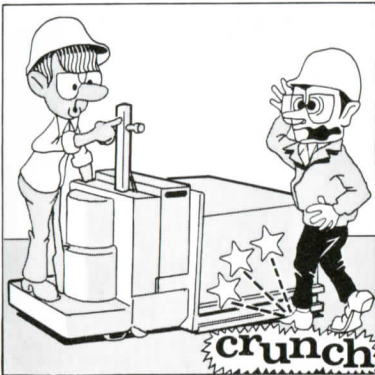

Code: OI-347 Aug 74

25. HWP model trucks are also equipped with a "lift" control button on the T-bar handle. This button should be operated exactly as described in item 24.

26. Always travel with load fully elevated to insure adequate floor clearance.

Never lift or lower load while truck is in motion.

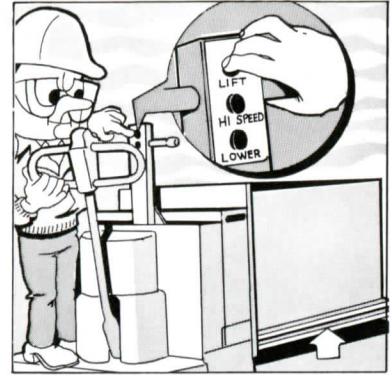

15208

13873

27. Never permit anyone to stand in area where load is being deposited.

Always make certain that area of load deposit is clear and uncluttered.

28. Load may be lowered by firmly pressing "lower" button and holding until load has descended to floor level.

Continue to hold "lower" button for 1-2 seconds after load reaches floor — then exit from pallet.

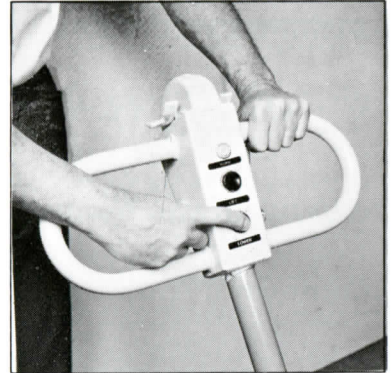



## Safety

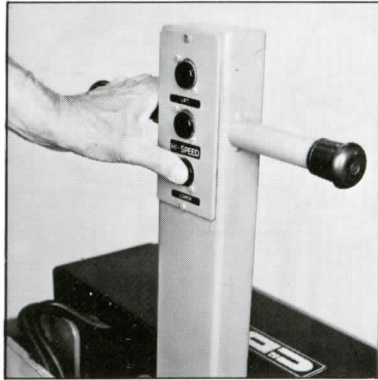

15183

29. HWP model trucks are also equipped with a "lower" control button on the T-bar handle.

This button should be operated exactly as described in item 28.

14681



31. Know and observe floor load limits in all operating areas.

Never enter an elevator, a boxcar, a semi-trailer or any other area until you have determined that the flooring will support you, your truck and its load.

30. Slow down for turns, ramps, bumps, cross aisles, congested areas, wet or slippery floors and at all times when visibility is restricted.

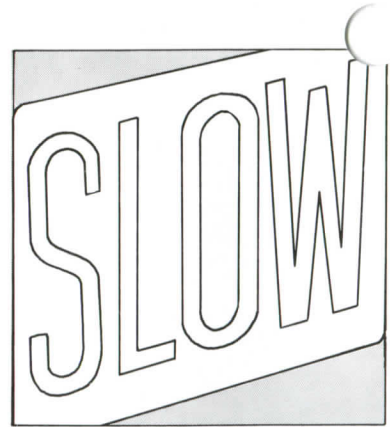

13103

13104

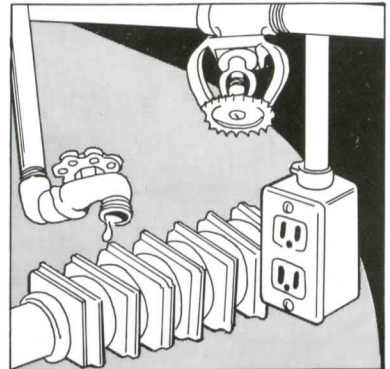

32. Use caution when picking up loads, placing loads or traveling near water pipes, electrical wiring, steam pipes, heaters or other fragile or dangerous material or equipment.

## Safety

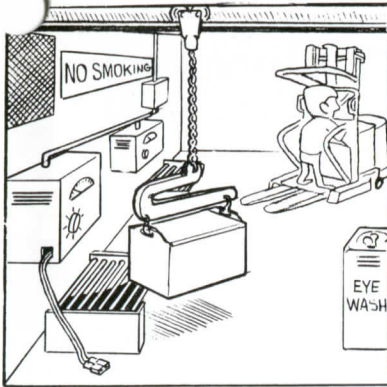

13105

15210

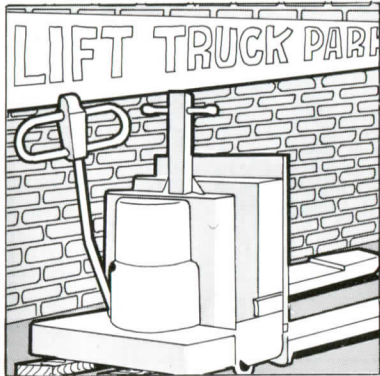

Code: OI-347 Aug 74

33. Batteries should be serviced or recharged only in designated charging areas and only by personnel thoroughly trained in safe battery servicing practices.

34. Never smoke or allow anyone to smoke in areas where batteries are being charged or in areas where fuel or other flammable fluids or materials are stored or used.



13107

13108

35. HWP (walk/ride) model trucks should be parked in designated areas only. Lower the forks to the floor, make certain control handle is in "full-up" position to apply brakes, remove key and block the drive wheel to prevent accidental roll.

36. If the HWP (walk/ride) model truck is to be left unattended for any reason, make certain that it does not obstruct aisles and leave the truck as described in item 35.

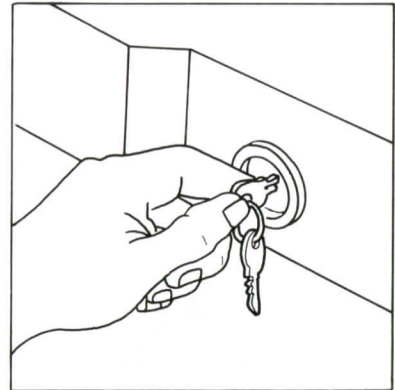

Page 11

## Safety

37. Know the construction type of your truck and never take an unauthorized truck into a restricted area.

38. Confined areas such as elevators, semi-trailers, trucks or box-cars must be entered in reverse (trail frame first) to minimize maneuvering necessary to exit.

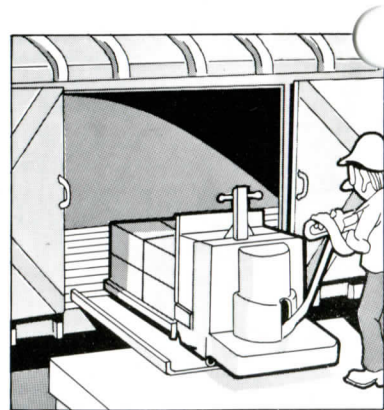

15211

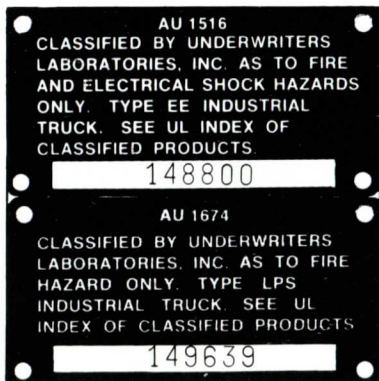

13178

15212



39. Remember to keep your feet well away from the front skirt and rider platform when maneuvering the HWP (walk/ride) model truck.

40. When moving up or down a grade, the forks should be kept downgrade with or without a load on the truck. The operator should control the truck from a walk position when on a grade.

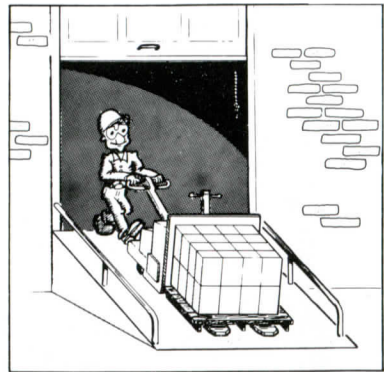

21498

## Safety



15016

41. Be constantly alert for unusual noises or erratic operation.

Report any malfunction immediately so that required adjustments or repairs may be made by thoroughly trained and qualified personnel.



15184

42. Follow a scheduled planned maintenance and lubrication program.

All adjustments and repairs must be performed by thoroughly trained and authorized personnel.

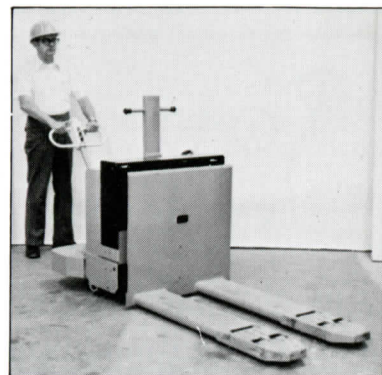

15017

43. Remember — your safety and the safety of others depends on you.

Keep your mind on operating your truck.



# Operator's Controls

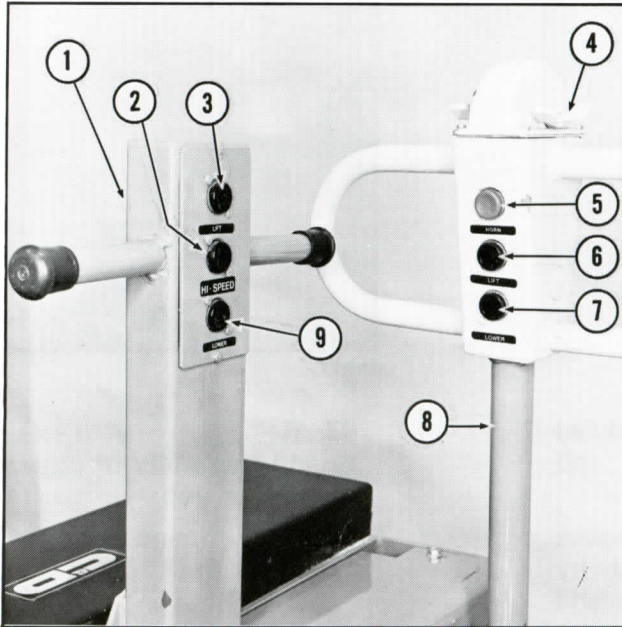

15185

1. T-Bar Control Handle.
2. Hi-Speed Switch.
3. T-Bar "Lift" Control Button.
4. Forward-Reverse and Speed Control.
5. Horn Button.
6. "Lift" Control Button.
7. "Lower" Control Button.
8. Steering Control Handle and Brake.
9. T-Bar "Lower" Control Button.



# Before Operation

CLARK ELECTRIC TRUCK DRIVER'S DAILY CHECKLIST	
Check Before Start Of Each Shift	
Truck No. _____	Date _____
Operator _____	Supervisor's OK _____
Hour Meter Reading _____	
Start of Day _____	End of Day _____ Hrs. for Day _____
<input checked="" type="checkbox"/> Boxes Accordingly <input type="checkbox"/> OK <input type="checkbox"/> Needs Attention or Repair	
<b>Visual Checks:</b>	<b>Operational Checks:</b>
<input type="checkbox"/> Obvious damage and leaks <input type="checkbox"/> Tire condition <input type="checkbox"/> Battery plug connection Note: Be sure the battery plug connection is tight. <input type="checkbox"/> Head and tail lights <input type="checkbox"/> Warning lights <input type="checkbox"/> Hour meter <input type="checkbox"/> Other gauges and instruments <input type="checkbox"/> Battery Discharge indicator Note: Key on, needle should indicate in green area.	<input type="checkbox"/> Horn <input type="checkbox"/> Steering <input type="checkbox"/> Service brakes <input type="checkbox"/> Battery Load Test Note: Watch battery indicator while holding tilt lever on full back tilt. If needle falls to red area, battery doesn't have sufficient charge to operate truck properly. <input type="checkbox"/> Parking brake <input type="checkbox"/> Seat brake <input type="checkbox"/> Hydraulic controls

13124

13874

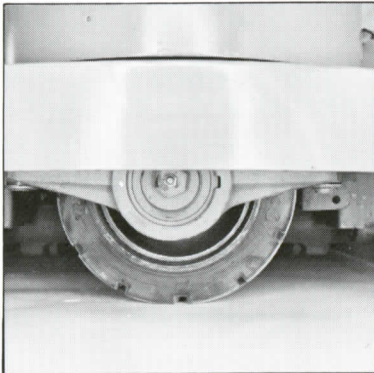

Code: OI-347 Aug 74

1. Each shift operator must complete an operator's daily check list (available from your Clark Dealer).

3. Check condition of drive wheel and tire assembly.

2. Walk completely around your truck and visually check for damage and leaks.

Note all damage and leaks on the operator's daily check list.



15214

15186

4. Move control handle vertically from "full-up" to "full-down" and return to "full-up" position while checking brake application. Truck brakes should be firmly applied at both extremes of handle travel.



## Before Operation



15187

5. Lower control handle to comfortable operating position and check steering by swinging handle through full 180° arc from right to left. Handle should move smoothly without noticeable binding.

6. Visually check battery connector to make sure that battery has been properly connected.

Note condition of electrical cables and wiring and report all worn, frayed or cracked cables to proper authority.

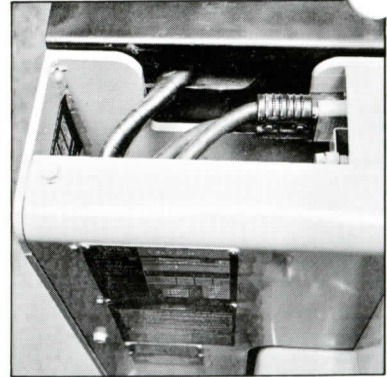

13877

13878

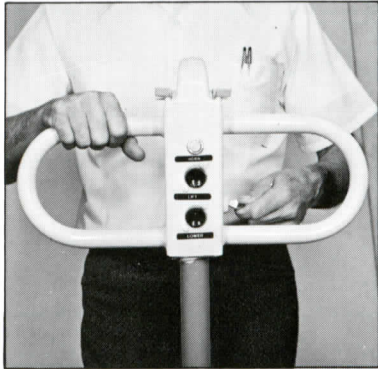

7. If your truck has been equipped with a key switch, insert key and turn switch clockwise to the "on" position.

If your truck has no key switch proceed to step 9.

8. If your truck has been optionally equipped with an hour meter, check to make certain that it is undamaged and functioning properly.

Note any hour meter damage or malfunction on the check list.

13225

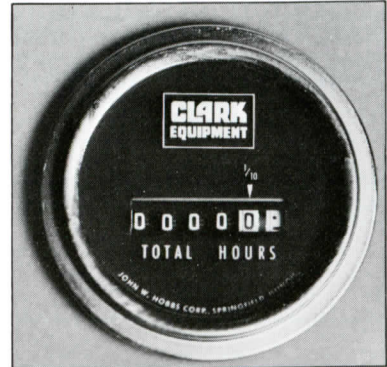

## Before Operation

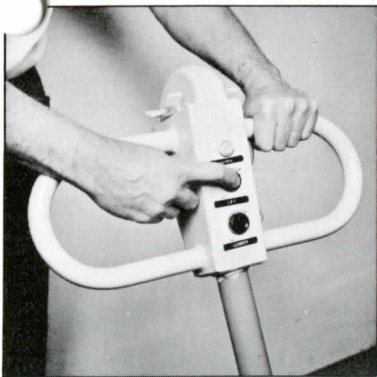

13872

9. Check to insure that pallet forks are unobstructed then press firmly on the "lift" button and hold until forks have elevated to maximum height. Release pressure on "lift" button to stop fork elevation at desired height.

10. Release the control handle in "full-up" position (to apply brakes) then walk to pallet fork end of truck and check condition of load wheels and tires.

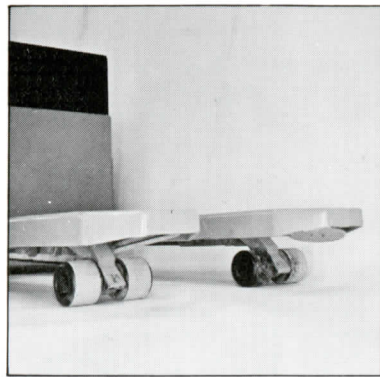

13879

13880

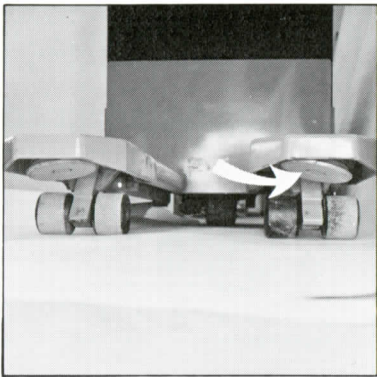

11. HWP (walk/ride) model trucks will be equipped with pallet entry discs (arrow) and exit rollers (located behind the load wheels in this photo). Check the condition of these items and note to your check list.

12. Return to control handle end of the truck and press "lower" button. Hold button until forks have lowered to maximum down position. Release pressure on "lower" button.

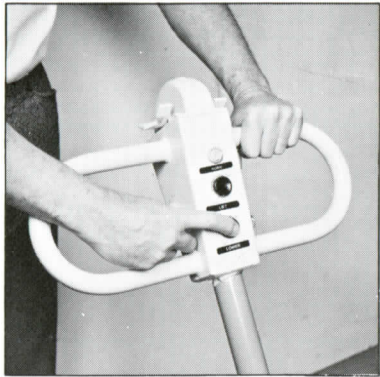

13873



## Before Operation

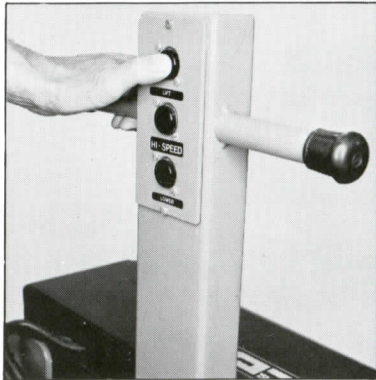

13. HWP (walk/ride) model trucks are equipped with an additional "lift" control button on the T-bar handle. This button should be checked as described in item 9.

15020

13881

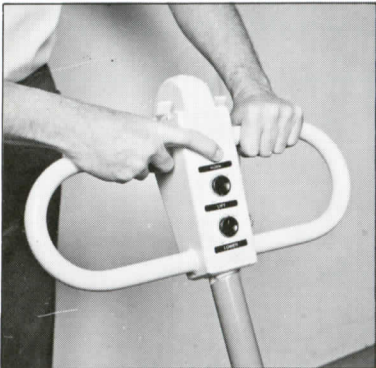

15. Press horn button (mounted on top of control handle head) to determine if horn is operational.

If horn does not function properly, note it on operator's daily check list.

Page 18

14. HWP (walk/ride) model trucks are equipped with an additional "lower" button on the T-bar handle. This button should be checked as described in item 12.

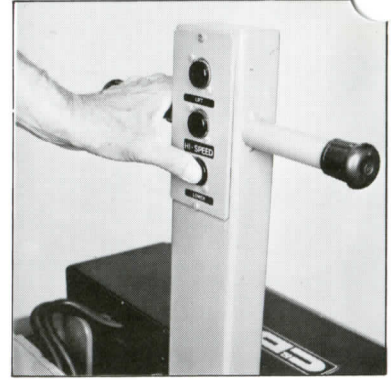

15183

15188

16. Pull control handle down to comfortable operating level and swing into position in line with desired path of forward or reverse travel.



Code: OI-347 Aug 74

## Before Operation

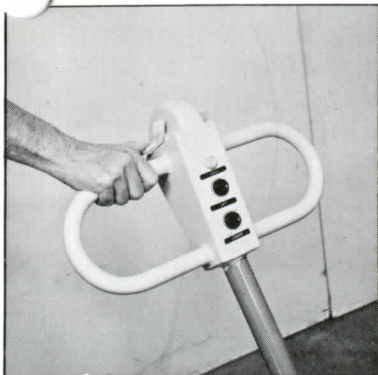

13883

17. Place thumb of right (or left) hand on lower "wing" of directional control switch and press gently. Truck will move forward (toward you) slowly. Travel speed may be increased by further pressing the switch "wing".

18. Release thumb pressure on lower directional control "wing" and raise handle to apply truck brake and stop forward travel.

Note any unusual or faulty operation on check list.



15189

13885

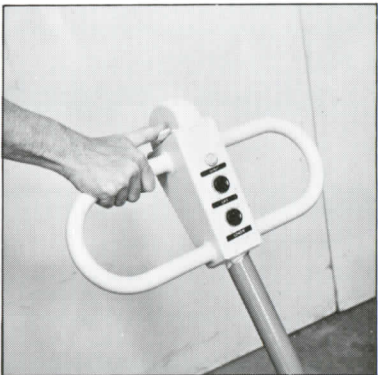

19. Lower handle to comfortable operating level and place thumb of right (or left) hand on upper "wing" of directional control switch. Press switch "wing" gently and truck will move in reverse (away from you).

20. Stop the truck as described in item 18 (on this page) and carefully step up onto the "rider" platform.



15190

## Before Operation



21. Make certain that your feet are well positioned on the rider platform and that they do not stick out beyond platform edges.

15191

15194

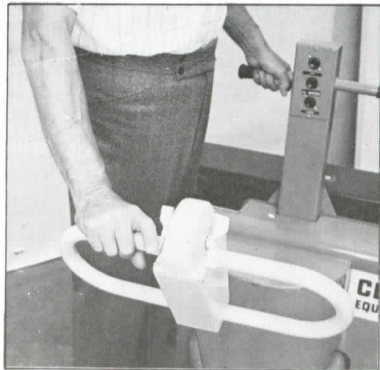

23. Place either hand on T-bar handle and the index finger of your other hand on the lower "wing" of the directional control switch.

22. Push control handle away from you to release brake.



15192

15193

24. Make certain that your path of travel is unobstructed. Then slowly and smoothly press down on switch wing. Truck will begin to move forward slowly and speed will increase as switch wing is pressed further.

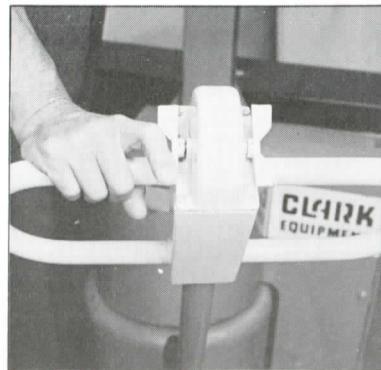



## Before Operation

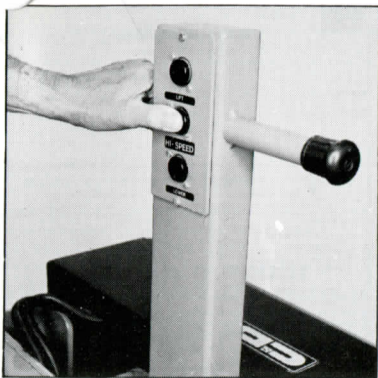

15019

25. When control handle switch "wing" has been fully depressed truck speed may be additionally increased by depressing "hi-speed" button located on the T-bar handle.

26. Release "hi-speed" button, release pressure on directional-speed control switch "wing" and smoothly pull control handle toward you to apply brake and stop truck.



15192

15190



27. When truck comes to complete stop — carefully dismount from rider platform.

28. Lower pallet forks to floor by pressing "lower" button and holding until forks lower fully.

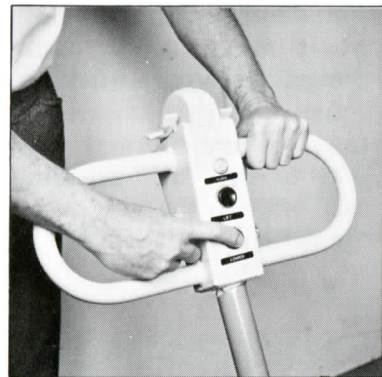

13873

# Before Operation

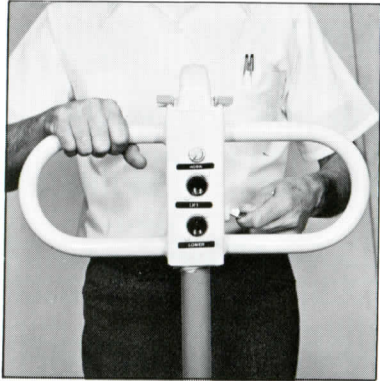

13878

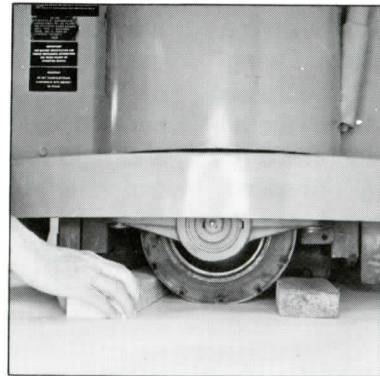

13886

29. Make certain that control handle is in "full-up" position to apply truck brakes. If your truck is equipped with a key switch turn the key counterclockwise to the "off" position and remove the key from the switch.

30. Move the control handle to a full turn position and block the drive wheel to prevent accidental roll.

CLARK EQUIPMENT	
<b>ELECTRIC TRUCK DRIVER'S DAILY CHECKLIST</b> Check Before Start Of Each Shift	
Date _____	
Truck No. _____	Supervisor's OK _____
Operator _____	
Hour Meter Reading: _____	
Start of Day _____	End of Day _____ Hrs. for Day _____
<input checked="" type="checkbox"/> Boxes Accordingly <input type="checkbox"/> OK <input type="checkbox"/> Needs Attention or Repair	
<b>Visual Checks:</b>	<b>Operational Checks:</b>
<input type="checkbox"/> Obvious damage and leaks	<input type="checkbox"/> Horn
<input type="checkbox"/> Tire condition	<input type="checkbox"/> Steering
<input type="checkbox"/> Battery plug connection	<input type="checkbox"/> Service brakes
<b>Note:</b> Be sure the battery plug connection is tight.	<input type="checkbox"/> Battery Load Test
<input type="checkbox"/> Head and tail lights	<b>Note:</b> Watch battery indicator while holding tilt lever on full back tilt. If needle falls to red area, battery doesn't have sufficient charge to operate truck properly.
<input type="checkbox"/> Warning lights	<input type="checkbox"/> Parking brake
<input type="checkbox"/> Hour meter	<input type="checkbox"/> Seat brake
<input type="checkbox"/> Other gauges and instruments	<input type="checkbox"/> Hydraulic controls
<input type="checkbox"/> Battery Discharge indicator	
<b>Note:</b> Key on, needle should indicate in green area	

13124

31. Then, review operator's daily check list to make certain that it has been properly marked, sign it and turn it in to the proper authority.



## Operation

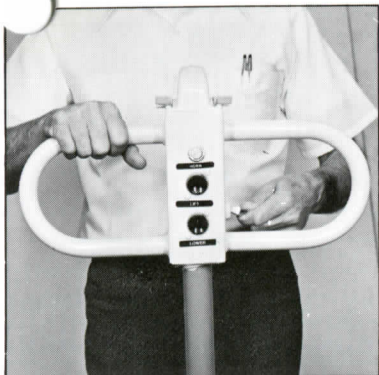

13878

13883

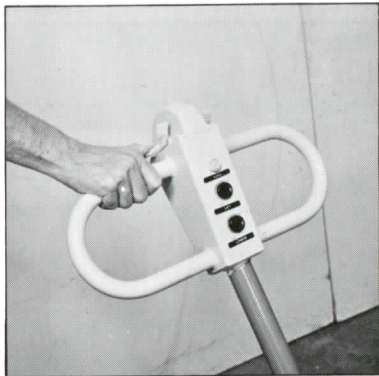

Code: OI-347 Aug 74

1. Remove blocks from drive wheel and swing control handle from full turn position to center of truck.

If your truck is equipped with a key switch — insert key and turn clockwise to "on" position.

3. Place thumb of right (or left) hand on directional control switch "wing" for desired direction of travel. Upper "wing" for reverse (away from you) or lower "wing" for forward (toward you).

When switch "wing" is depressed truck will begin to move. Truck speed will increase as switch "wing" is further depressed.

2. Lower control handle to comfortable operating level and check to be certain that desired path of travel is unobstructed.

Press "lift" button and hold until pallet forks have raised to maximum height.

4. To stop truck release directional control switch "wing" (allowing switch to return to neutral) and raise control handle to near vertical position. (This will activate switch cutting power to drive motor and apply brakes).

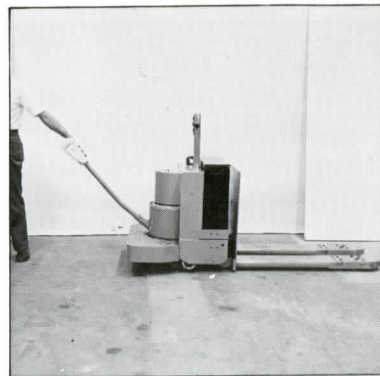

15188

15189



## Operation



5. Remember to wait until truck comes to a complete stop before attempting to step up onto the rider platform, then step onto platform with caution.

15190

6. Make certain that your feet are well back from the rider platform edge and push forward (away from you) on the control handle to release truck brake.



15191

15193

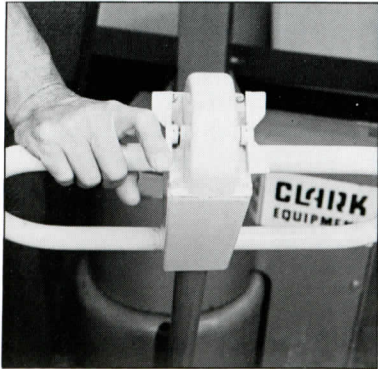

7. With index finger of hand on control handle slowly press down on lower "wing" of directional-speed control switch. Continue to press switch "wing" until truck has accelerated to desired speed.

8. If additional truck travel speed is required at this point, press the "hi-speed" button with thumb of whichever hand you have on the T-bar handle.

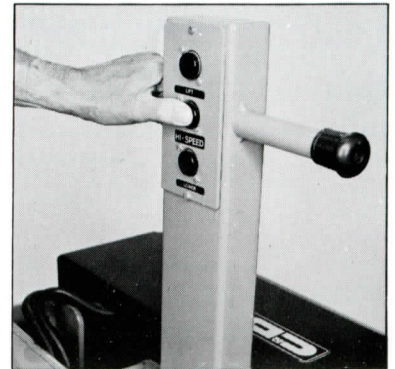

15019

## Operation



15192

14680

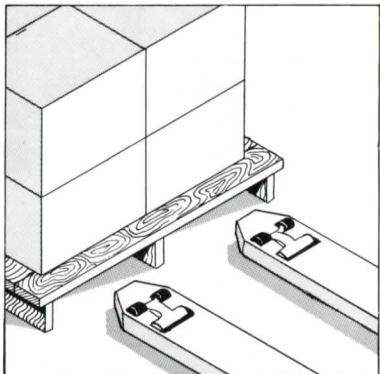

9. Release thumb pressure on "hi-speed" switch button, release index finger pressure on directional-speed control switch "wing" and gently pull control handle toward you to apply brake and smoothly stop truck.

11. Lower pallet load forks before entering load and remember to center load on forks as you approach it. Always enter the load as far as possible.

10. When truck comes to complete stop, carefully dismount from rider platform. Walking control of HWP models is strongly recommended when negotiating ramps, picking up or depositing loads and when maneuvering the truck in close quarters.

12. Before lifting the load make certain that the lifting area is unobstructed. Then, press "lift" button and hold until load reaches full lift height.



15190

13664

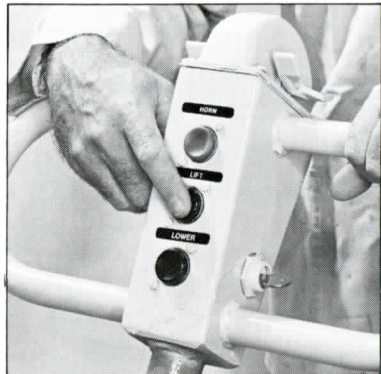



## Operation

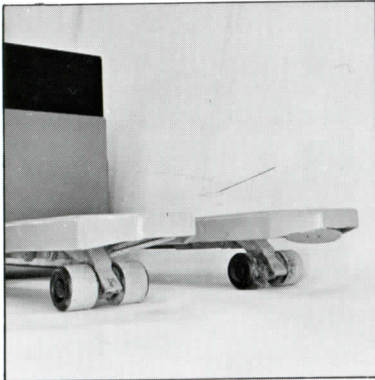

13879

13. Remember to travel with load fully elevated to provide maximum clearance. This will reduce the possibility of load pallet contact with the floor and its irregularities (if any).

14. Always use caution when making right or left turn into aisle. HWP load wheels do not follow the turn path of the drive wheel. They will tend to "cut" the corner.

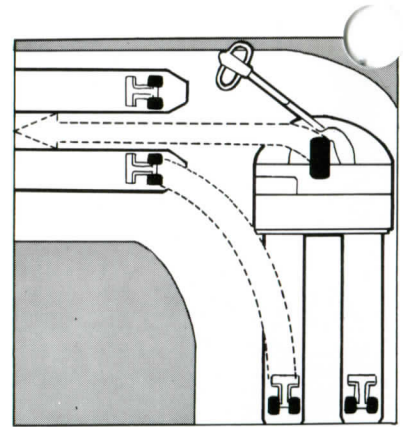

14689

15211

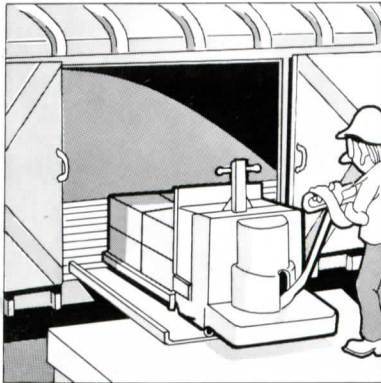

15. Enter confined areas such as semi-trailers, trucks, boxcars or elevators with load end of your truck first.

This will minimize the maneuvering necessary to exit.

16. When moving up or down a grade, the forks should be kept downgrade with or without a load on the truck. The operator should control the truck from a walk position when on a grade.

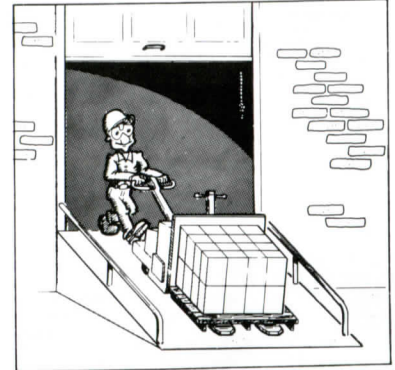

21498

## Operation

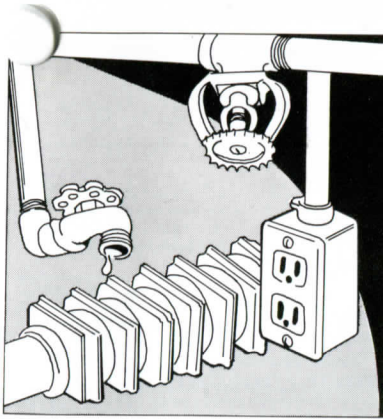

13104

17. Always approach load deposit areas squarely and cautiously. Be especially careful when placing loads near water pipes, electrical wiring or outlets, steam pipes, heaters and other fragile or dangerous equipment or material.

18. When load to be deposited has been positioned as desired, press "lower" button and hold until pallet forks are lowered as far as possible.

Hold "lower" button for 1-2 additional seconds before exiting from pallet.

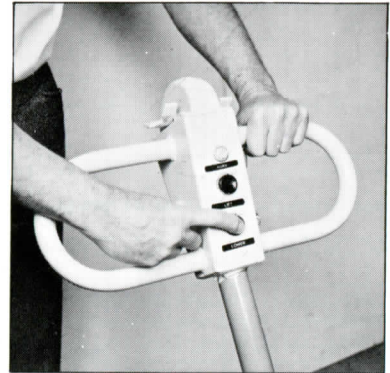

13873

13883

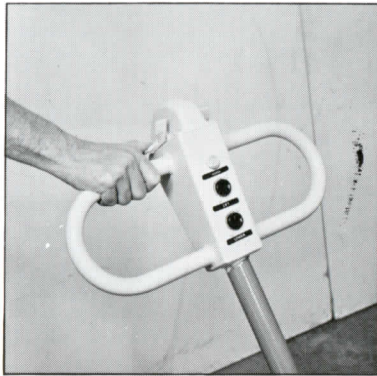

19. Pull control handle down to comfortable operating level, depress directional control switch lower "wing" gently.

Truck will move forward (toward you) withdrawing the truck forks from the pallet.

20. Be alert for unusual or erratic truck operation.

Report any malfunction immediately so that required adjustments or repairs may be performed by thoroughly trained and qualified personnel.

15184



## Parking

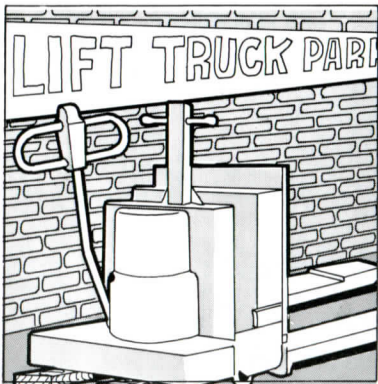

15210

1. Park HWP (walk/ride) model trucks in designated parking areas only.

Do not obstruct traffic lanes or aisles.

15195



3. Place control handle in full turn and raise handle to "full-up" position so that truck brake is applied.

2. Lower pallet forks to floor or as near to the floor as possible.

4. If your truck is equipped with key switch turn key counterclockwise to "off" and remove key.

Block drive wheel to prevent accidental roll.

Turn key in to proper authority.

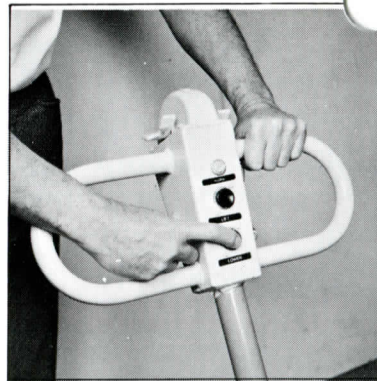

13873

13886

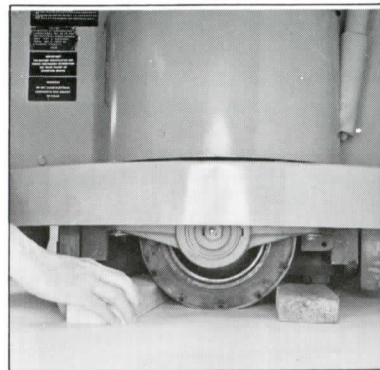

# For Handy Reference

RECORD THE FOLLOWING INFORMATION PERTAINING TO YOUR TRUCK

Model No. ....

Serial No. ....

Attachments .....

Truck Weight W/Battery .....

Truck Rated Capacity .....

Gross Truck Weight (W/Battery and Rated Load) .....

Customer Truck Identification No. ....



Additional copies of this manual may be purchased from  
YOUR AUTHORIZED CLARK DEALER

---

---

**CLARK** Industrial Truck  
Division

Asheville, NC 28776  
Battle Creek, MI 49016  
Georgetown, KY 40324  
St. Thomas, Ontario, Canada N5P 1H2

1.3M APR 84 Printed in U.S.A.